



Installation/Operation/Maintenance Manual and Reference Guide

Heater Models



**RA 350
RAD 350**



**RA 500
RAD 500**



CSA Certified to Electrical and Fuel Burning requirements only.

IMPORTANT Notice to Owner and Installer

To ensure the long term benefits of burning your used oil in a Reznor® Used-Oil-Fired Heater, it is necessary to become familiar with the correct installation and maintenance of your new heater. Before installing or operating this heater, make sure you have read and understand this manual.

IMPROPER INSTALLATION OR LACK OF MAINTENANCE WILL VOID THE WARRANTY.

The most critical sections of this manual are

- Correct Draft Over Fire - Page 21
- General Maintenance Requirements - Page 24

Identical to any gas or oil burner, without adequate draft over the fire, the combustion gases cannot escape resulting in an overheated combustion chamber. Even if the burner is installed correctly and adequate draft achieved, a flue passage blockage will affect the draft. Burning used oil is similar to burning wood. A fine gray ash accumulates in the chamber and flue passages. This accumulation of ash will eventually affect the draft. It is important to remove this ash before the draft is affected.

These topics are discussed in detail on the pages listed above. Please familiarize yourself with these sections of your manual. Spending a few minutes to review this material will assure that you receive the return on investment that you expect from your heater.

Installation

Introduction

Use

This heater is for commercial or industrial use only.

The heater should be installed by an experienced installer thoroughly trained and experienced with the installation of oil-fired appliances. The installer should be familiar with the special precautions necessary in the handling and storage of used automotive oils which may contain small amounts of gasoline.

Codes and Regulations

Installation must comply with:

In the United States

- The Standard for the Installation of Oil Burning Equipment NFPA 31
- The National Electrical code ANSI/NFPA 70
- Federal, State, and local municipal codes

In Canada

- CSA Standard B139-M91, Installation Code for Oil Burning Equipment
- CSA Standard C22.1-Canadian Electrical Code, Part 1
- Federal, Provincial, and local municipal codes
- Installation, operating and maintenance permits may be required from regulation authorities covering environmental quality fuel, fire and electrical safety. Municipal permits may also be required.
- Regulation requires that only used oil generated on the premises of the owner may be burned in this equipment unless written authorization is obtained from the regulatory authority.

Warranty

For Warranty information, refer to the Limited Warranty form in the Literature Bag.

WARRANTY IS VOID IF

1. Heater is not installed in accordance with these instructions and applicable codes and ordinances.
2. Wiring is not in accordance with diagram furnished with the heater.
3. Heater is operated in presence of chlorinated vapors.
4. Air through the heater is not in accordance with the rating plate.
5. Ducts are attached to RA (fan) model
6. Heater is not maintained in accordance with maintenance requirements. **FAILURE TO CLEAN THE COMBUSTION CHAMBER ON A REGULAR BASIS.**
7. Other-than-specified fuel is burned.
8. Heater is operated at elevations greater than 3,000 ft (914M) above sea level without factory approved modifications.
9. Fuel input capacity is altered.

Safety Warnings



Conventions Used in this Manual

Hazard Intensity Levels

DANGER: Failure to comply will result in severe personal injury or death, and/or property damage.

WARNING: Failure to comply can result in severe personal injury or death and/or property damage.

CAUTION: Failure to comply could result in minor personal injury and or personal damage.

NOTE: Additional Warnings are also included throughout this manual.

Secondary Heat Source

CAUTION: These heaters are designed to provide economic disposal of used oils. Used oil is an inconsistent fuel and may contain water and/or foreign materials which may cause the unit to shut down. A secondary source of heat should always be provided to the building; do not depend on this heater as your only source of heat. This will prevent building damage should the heater become inoperable during sub-freezing weather.

Fuels

WARNING: Approved fuels are No. 2 fuel oil and used automotive transmission fluid and crankcase oils up to 50 weight. Do not attempt to burn any grade of gasoline, paint thinner, or non-approved fluids. Adequate ventilation must be provided in any enclosure where storage tanks, pumps, or accessories are installed.

Hazardous Atmosphere

This heater is not designed for use in hazardous atmospheres containing flammable vapors or combustible dust, or atmospheres containing chlorinated or halogenated hydrocarbons.

Venting

WARNING: Failure to provide proper venting could result in death, serious injury, and/or property damage. Units must be installed with a flue connection, draft regulator and proper vent to the outside of the building. Safe operation of any gravity vented heating equipment requires a properly operating vent system, correct provision for combustion air, and regular maintenance and inspection.

Safety Warnings Continued

Air for Combustion

WARNING: Care should be exercised to ensure that an adequate supply of combustion air is available and free to enter the air openings on all units. Room openings must equal one square inch per each 1,000 BTU heat input.

Non-Compliance

Failure to install or maintain this heater properly will void the warranty.

Unpacking and Inspection

Check the heater for any damage that may have occurred in shipment! If damage is found, file a claim with the transport company. Your unit was inspected and tested at the factory prior to crating and was in perfect condition at that time. Open the boxes and verify receipt of all parts.

To protect the unit during shipping, the blower model (RAD) has special supports that must be removed before installation.

- Blower support legs - Remove the four blower support legs and screws.
- Check Belt Tension - Belt should be able to be depressed 1/2" - 3/4" (See illustration below.) If the belt does not have proper tension, adjust by means of the adjusting screw on the motor base. After proper tension is achieved, tighten the lock nut on the adjusting screw.
- Replace the belt guard.

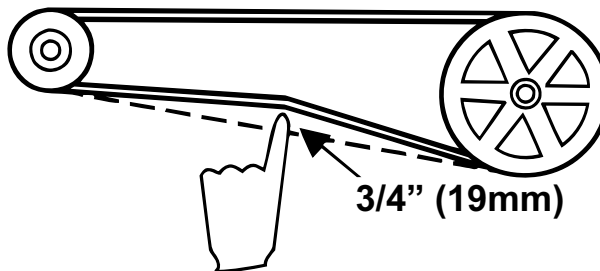

Fan Models (RA) use plastic cable ties to support the fan motors during shipment. Cut and remove prior to installation.

Additional Parts

Shipped with each heater is a remote fuel pump and a carton of parts. The carton contains parts required for installation. Before beginning actual installation, verify that the remote fuel pump and the parts listed below are at the installation site.



Parts Carton

NOTE: Due to product development, items may not appear exactly as illustrated.

<u>Part No.</u>	<u>Description</u>
255350 ①	Thermostat
96388 ②	Oil Filter
135986 ③	Vacuum Gauge
110320 ④	Foot Valve
130952 ⑤	Oil Pump Inlet Manifold
37866 ⑥	Draft Regulator - RA/RAD 350
157623 ⑥	Draft Regulator - RA/RAD 500
121030 ⑦	Recycling Window Decal
121603 ⑧	Warning label (for inlet to fuel storage system/tank)
136864 ⑨	Foot Valve Strainer

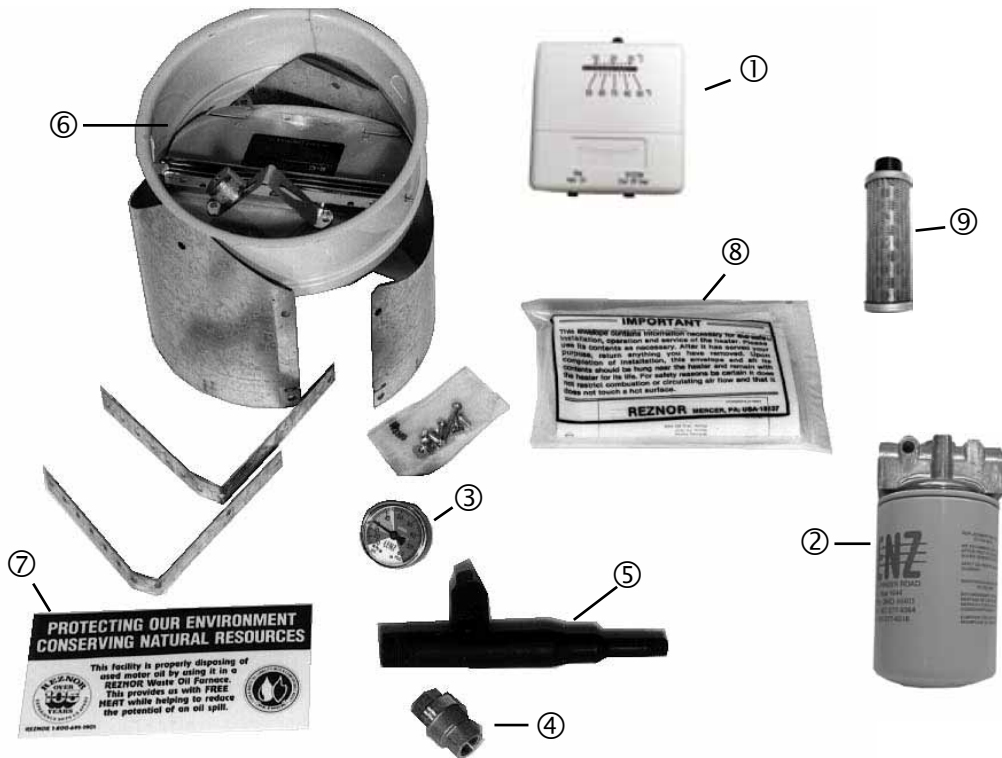

Heater Placement

Do not attempt to install this heater until you have read and understand this manual!

Placement is critical to the efficient operation of this heater.

Locate a specific central area for placement of your heater.

Measure all distances to comply with the specific code requirements and minimum clearances listed below.

Refer to the section on Venting your heater for vent requirements and recommendations.

Locate the heater so that suitable means shall be provided to facilitate regular cleaning and maintenance of the heater (i.e. permanent platform, portable stairs, ladder, etc.).

WARNING: You must comply with all requirements on distance from heater to combustibles.

Minimum Clearances from Combustibles

	Fan Models		Blower Models	
	RA350/500		RAD350/500	
	inches	mm	inches	mm
Top	6	152	6	152
Front	48	1219	48	1219
Side (Burner)*	18	457	18	457
Side (Opposite Burner)*	18	457	18	457
Rear*	24	610	6	152
Bottom	18	457	18	457
Flue Pipe	18	457	18	457

*Allow for service access.

In Canada, for additional information on installation clearances, refer to CAN/CSA-B139-M91, "Installation Code for Oil Burning Equipment," Clause 7.0 - Installation Clearances.

WARNING: Clearances apply to all combustibles. Do not leave paper, rags, or any moveable combustibles near the heater or store gasoline or any other flammable fluid near this appliance.

High Altitude Installation

High Altitude Installation

Standard Model RA/RAD 350 and 500 used oil heaters are designed for use from sea level up to elevations of 3,000 ft (914M). Without proper modifications severe overheating of the combustion chamber and heat exchanger will occur if installed above 3,000 ft (914M). Also, the onboard air compressor will not deliver the correct amount of atomizing air to the fuel nozzle, resulting in poor combustion. Models RA/RAD350 are available as factory-built high altitude heaters, identified with the suffix "H" (i.e. RA-350-H). Models RA/RAD500 are not available for elevations above 3000 ft (914M).

WARNING: Standard model used-oil-fired units installed above 3,000 ft (914M) elevation will overheat, damaging the heat exchanger assembly. Use of standard model heater above 5,000 ft (1514M) may result in incomplete combustion and formation of carbon monoxide (CO). Elevations above 3,000 ft (914M) require installation of a heater that is either factory-built or field converted for use at high elevation. Failure to comply can result in severe personal injury or death and/or property damage and will void the warranty.

Check the rating plate for the approved elevations.

Models RA/RAD350						
Elevation	Fuel Input		Heat Input		Heat Output	
	GPH	LPH	BTUH	kw	BTUH	kw
0-3,000 ft	2.5	11.4	350,000	102.6	190,400	55.8
>3,000 - 7,000 ft	2.1	9.5	294,000	86.2	138,880	65.9
Models RA/RAD500						
Elevation	Fuel Input		Heat Input		Heat Output	
	GPH	LPH	BTUH	kw	BTUH	kw
0-3,000 ft	3.6	16.4	500,000	146.5	400,000	117.2

If the heater is being installed above 3,000 ft, it must either be factory built (Model 350-H) for that elevation or be changed in the field. High Altitude Conversion Kits including all parts and instructions are available for Size 350 heaters.

The high altitude conversion affects both the remote pump and the heater. Install the high altitude kit prior to pump and heater installation.

Fuel Tank, Pump, and Supply Lines

General Requirements

Model RA/RAD 350 and RA/RAD 500 heaters are approved to burn used crankcase oil, transmission fluid, and No. 2 fuel oil. Maximum fuel input for a Model 350 is 2.5 GPH (11.4 L/H). Maximum fuel input for a Model 500 is 3.6 GPH (16.4 L/H).

The oil supply tank and fuel lines must be installed in accordance with the National Board of Fire Underwriters requirements and all local ordinances. A UL-listed tank such as Reznor® Model OT-250 or equivalent must be used.

In the U.S., regulations require that storage tanks located inside buildings shall not exceed 275 gallons (1,041 L) individual capacity or 550 gallons (2,082 L) aggregate capacity in one building.

In Canada, regulations require storage tanks located inside buildings shall not exceed 550 gallons (2,082 L) individual capacity or 1,100 gallons (4,164 L) aggregate in one building.

Check with the local Fire Marshal to assure compliance with local ordinances and codes. ***Installation of the tank and supply lines is the responsibility of the installer.***

Fuel Tank

Fuel Tank

CAUTION: It is recommended that used oil be at a temperature of 50°F or higher when it enters the pump. At a temperature below 50°F, heavier oils become more viscous and difficult to pump. The heater may fire at a reduced rate and become erratic resulting in nuisance shutdowns.

Install either a UL listed Reznor® Model OT-250 oil supply tank or a field-supplied equivalent indoor storage tank.

- If installing a Model OT-250 tank, follow the installation requirements and instructions on the tank.
- If installing a field-supplied tank, follow the manufacturer's instructions.
- Height from the pump to the bottom of the heater should be no more than 15 ft (4.5M). The used oil supply line should be a maximum of 60 ft (18M) in length when using 3/8" o.d. tubing or a maximum of 100 ft (30.5M) when using 1/2" o.d. tubing.

Although maximum height from the pump to the heater is 15 ft (4.5 M), we recommend that ease of service be considered when determining heater location. A service height of eight feet (2.5 M) is recommended. See the illustrations on pages 11 and 12 for examples of tank and line installation.

WARNINGS: Never pour gasoline or used oil containing gasoline into the supply tank. Adequate ventilation must be provided in any enclosures where storage tanks, pumps, or accessories are installed.

Pump



Remote Fuel Pump

The Model OT-250 tank has a platform designed for attaching the remote fuel pump.

- Attach the fuel pump legs permanently either on the platform, directly to a field-supplied tank, or in a location very near to the oil tank.
- Mount the remote pump assembly in an upright, horizontal position as shown in the illustration. **NOTE:** Motor enclosure appearance may be different than illustrated but must always be mounted in this upright position.

NOTE: Do not mount the pump assembly in a vertical or inverted position.

Supply Lines Installation

CAUTION: Do not use TEFLON® based pipe dope or TEFLON® tape to seal any pipe connections. (TEFLON® is a registered trademark of DuPont Chemical.) Use of TEFLON® based pipe dope or TEFLON® tape will void the pump warranty.

Supply Lines

Read this section carefully before installing any supply lines. Since a suction line leak is nearly impossible to find, take your time to assure all connections are leak-free during installation. **Supply lines and fittings are furnished by the installer.** See the following illustration for minimum fittings required. Length of pipe and tubing depends on the installation.

Run the suction line, using 1/2" standard black iron pipe, between the inlet side of the filter and the foot valve. (Refer to the illustration.) A fuel line filter with a cleanable strainer, a foot valve, a foot valve strainer, and a vacuum gauge are provided with the heater. To prevent air from entering the line, do not use union connections at joints. Install the suction line components as illustrated. With the vacuum gauge mounted

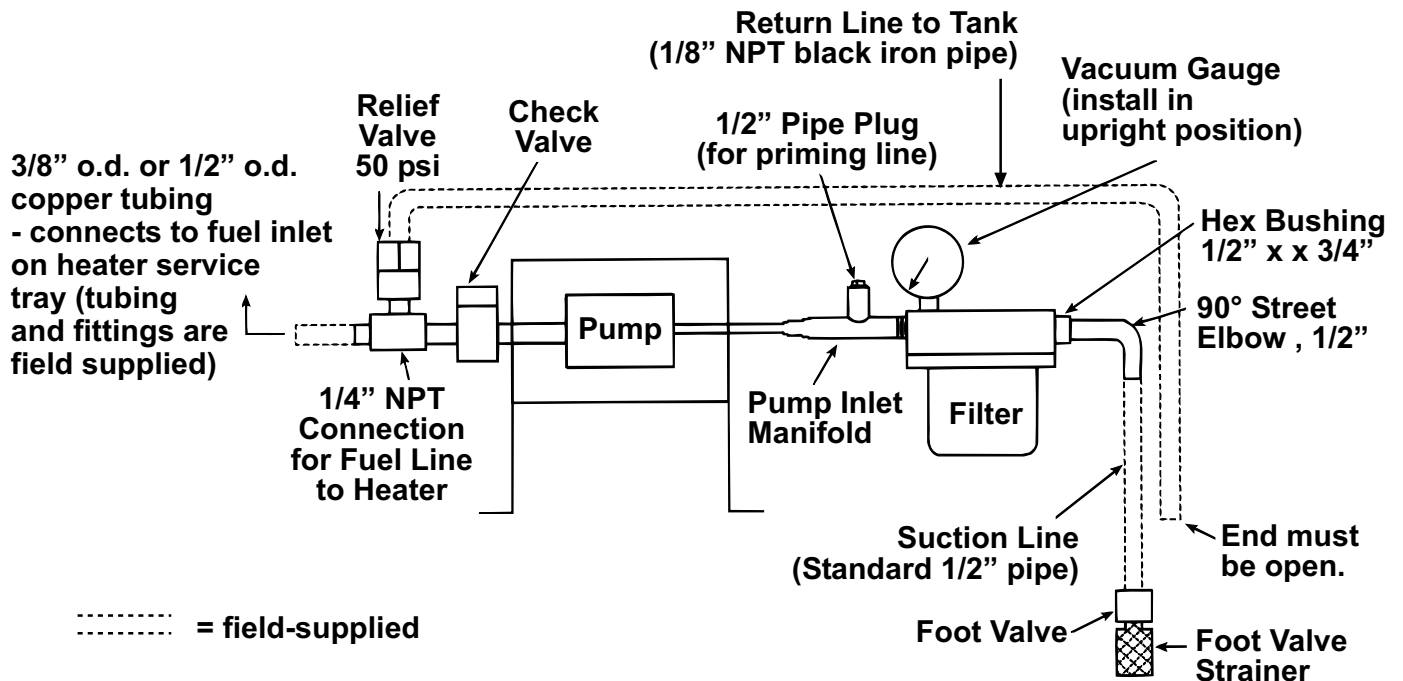

Supply Lines Installation Continued

on the outlet side of the filter, the gauge will indicate any suction line restriction including a dirty filter. A pump inlet manifold is supplied for direct connection of the filter to the inlet of the pump.

The supply line between the outlet side of the fuel pump and the heater should be either 3/8" o.d. or 1/2" o.d. copper tubing with a minimum of 1/32" wall thickness with 45° flare fittings. The supply line must continually rise. A lift height of up to 15 ft (4.5 M) is acceptable with a maximum total length of 60 feet (18 M) for 3/8" tubing or 100 feet (30.5M) for 1/2" tubing.

Do not install manual valves in the supply line.

Connect the fuel line to the heater at the connection on the corner of the service tray.

The 50 psi relief valve supplied with the pump and a return line of 1/8" NPT black iron pipe must be installed as illustrated. All piping should be protected from possible damage and be rigidly fastened in place in a workmanlike manner. Do not use TEFLON® based pipe dope or TEFLON® tape at the connections in an oil line. Use an oil-resistant pipe dope. Do not use union connections in the suction line (line between the oil supply and the remote pump); union connections are not recommended for use in any portion of an oil supply line.

NOTE: Care must be exercised to ensure airtight connections.

Typical Installation

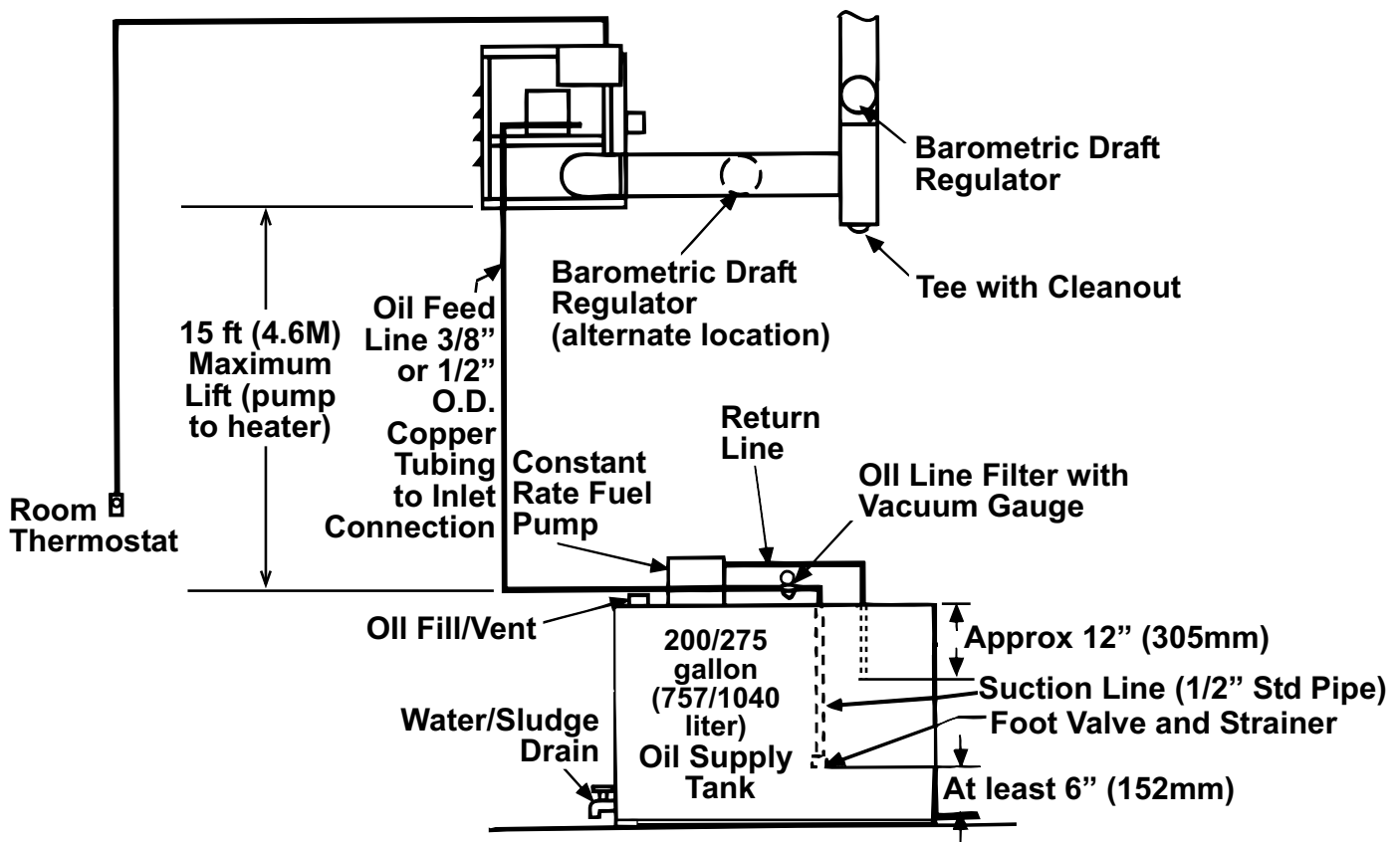

Mounting the Heater

Weights

Before suspending the unit, check the supporting structure to ensure it has sufficient load-carrying capacity to support the weight of the heater.

Model	Net Weight	
	lbs	kg
RA350	525	238
RA500	750	340
RAD350	650	295
RAD500	850	386

Suspension

Use four 1/2"-13 diameter threaded rods. Lock each threaded rod using a washer and nut as shown in the illustration below. Or, use optional swivel connections (Option CK10) and field-provided 1" threaded pipe. Lock swivel connections as shown in the illustration. Remove the shipping crate bottom from the unit.

Remove the angle clips and re-insert the screws into the heater cabinet.

WARNING: This heater must be supported level for proper operation. Do not place or add additional weight to the suspended heater.

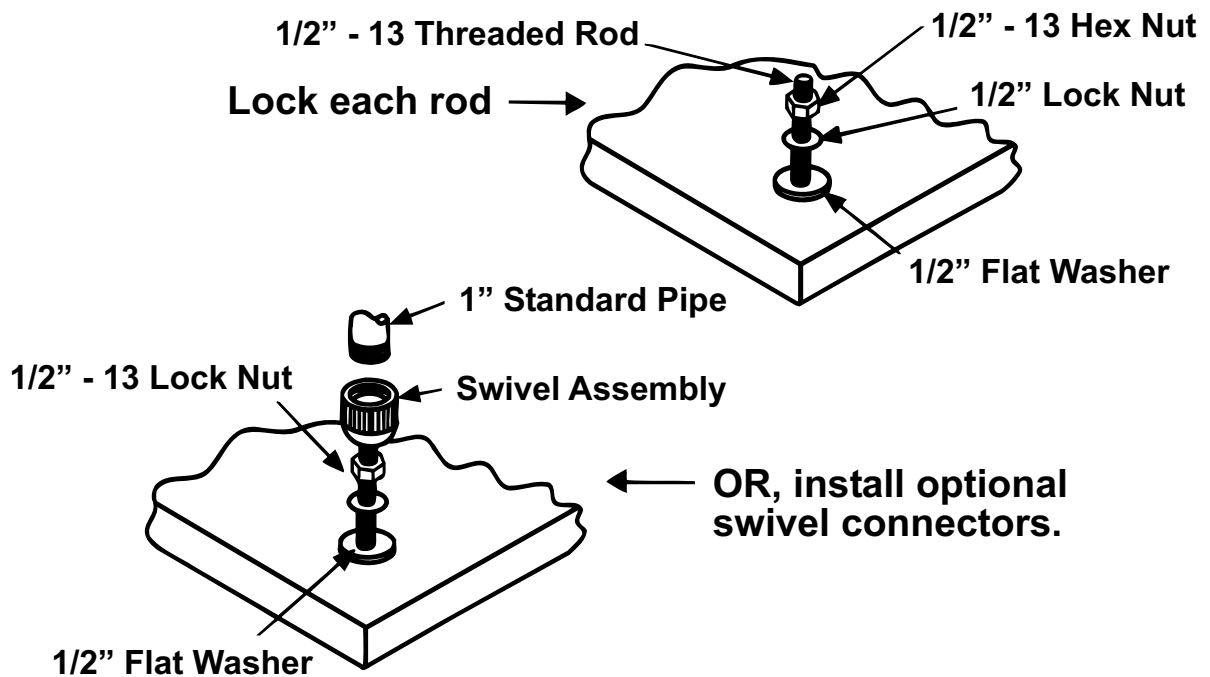

Venting the Heater

Guidelines for the Vent System

WARNING: Failure to provide proper venting could result in death, serious injury, and/or property damage. Units must be installed with a flue connection and proper vent to the outside of the building. Safe operation of any gravity vented heating equipment requires a properly operating vent system, correct provision for combustion air, and regular maintenance and inspection.

The vent system must comply with all local codes and in the event that local codes do not exist, the vent system must comply with a regional or national code.

The requirements for the vent system are dependent on (1) the location of the heater within a building and (2) the type of building.

- If the heater and the vent system are within the same heated space, single wall pipe may be used inside the building. The portion of the vent system outside the building must be a factory-built vent that is approved to Standard UL 641. See illustration below.

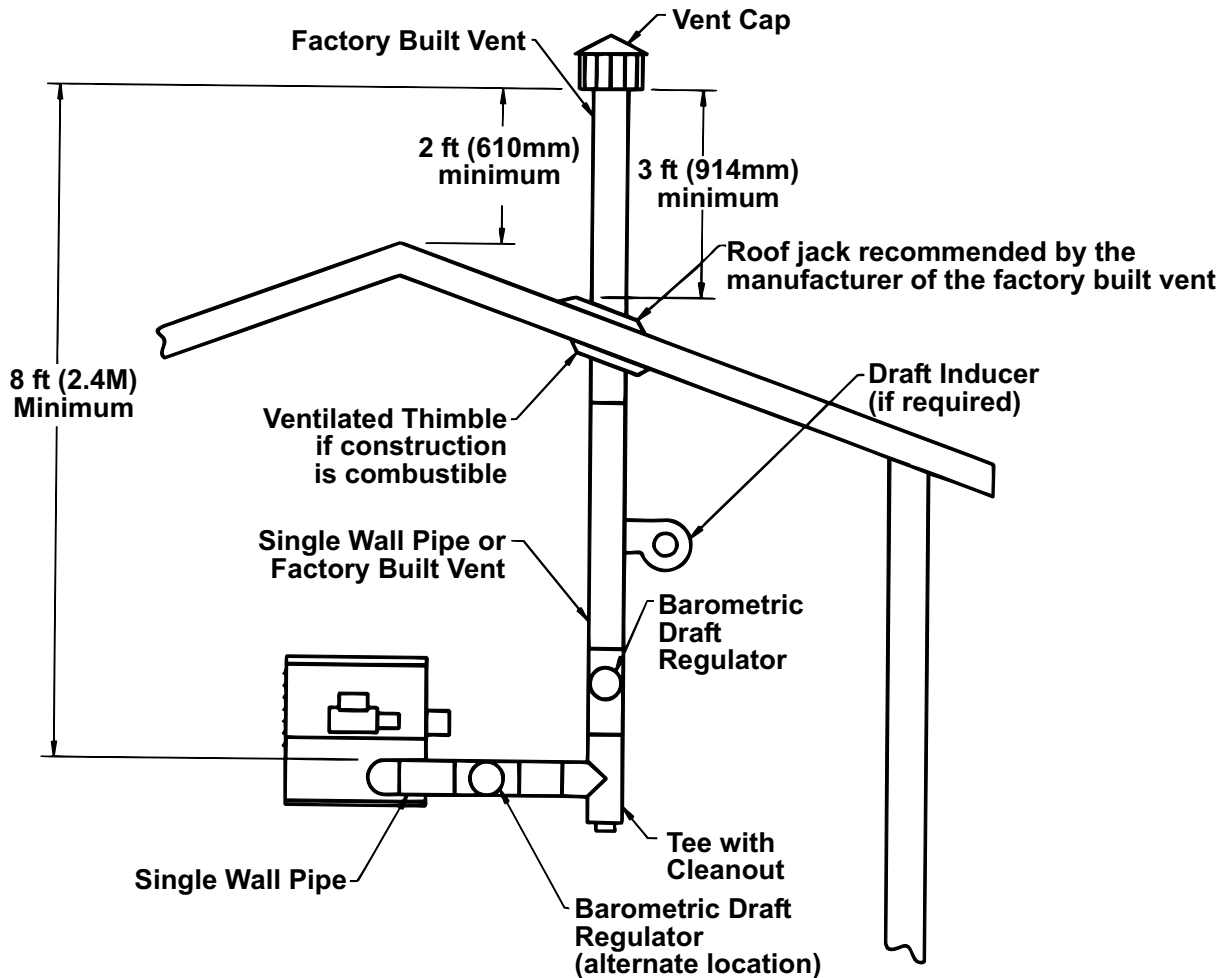

- Any portion of the vent system that passes through an unheated space or a concealed area such as an “attic” must be a factory-built vent that is approved to Standard UL 641. See illustration
- The heater may be vented into a masonry chimney that complies with the BOCA National Mechanical Code for low-heat appliances or other building code requirements for low-heat appliances.

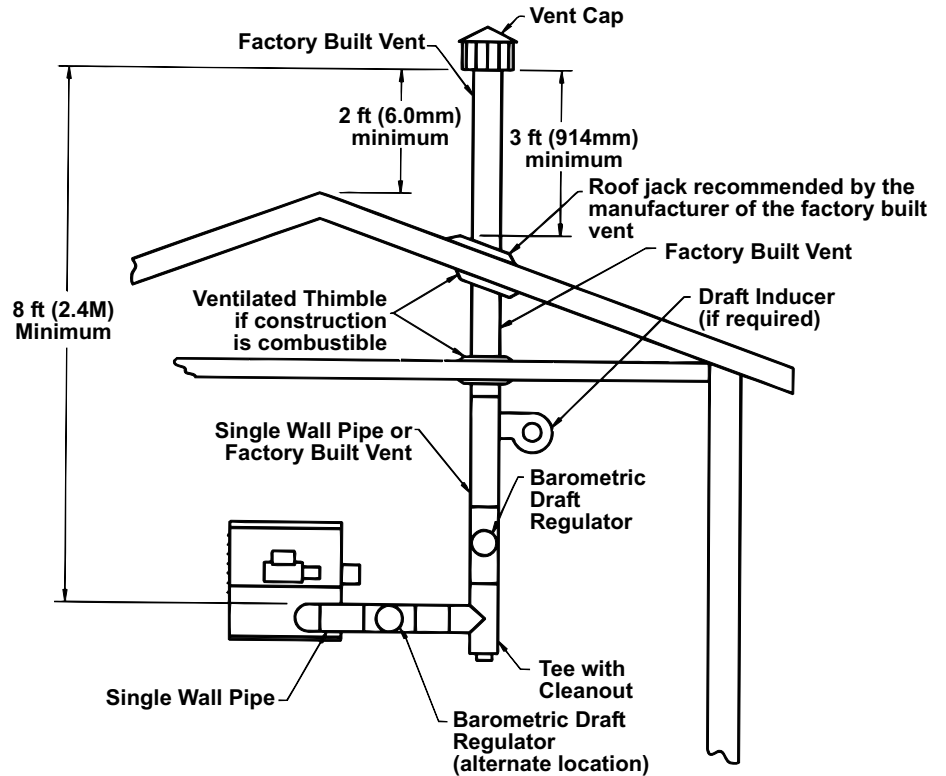

Detailed Requirements for the Vent System

(read all before beginning installation)

- **Pipe/Joints/Clearances:** Single-wall pipe must be a minimum of 24 gauge galvanized steel for 8” or 9” diameter pipe and 22 gauge for 10” or 12” diameter pipe. Each joint must be secured with three screws or rivets. If installing a factory-built vent, follow the manufacturer’s instructions.
If the vent system passes through a combustible wall, material or roof, for single wall pipe, maintain 18” (457mm) clearance or install a ventilated thimble that is not less than 12” larger than the diameter of the vent pipe. If installing factory-built vent, follow the manufacturer’s instructions.
- **Horizontal Length and Slope:** The horizontal portion of the vent must comply with the maximum horizontal length shown in the table below and have not more than two elbows except where noted that the application is limited to one elbow. Horizontal portions must be sloped upward 1/4” for each foot of pipe. If installation conditions require horizontal lengths in excess of those permitted in the table, a draft inducer must be used.

Vent Pipe Diameter	Model Size and Vertical Length	Maximum Length of Horizontal Pipe
8”	350 with 8 feet (2.4M) of vertical pipe	3 feet (.9M) or less and only one elbow
8”	350 with 12 feet (3.7M) of vertical pipe	6 feet (1.8M) or less
8”	350 with 14 feet (4.3M) or more of vertical pipe	Equal to or less than the vertical height
10”	350 with 8 feet (2.4M) or more of vertical pipe	Equal to or less than the vertical height
10”	500 with 8 feet (2.4M) of vertical pipe	3 feet (.9M) or less and only one elbow
10”	500 with 10 feet (3M) of vertical pipe	5 feet (1.5M) or less
10”	500 with 12 feet (3.7M) or more of vertical pipe	Equal to or less than the vertical height

- **Vent Size:** The vent system must be at least 8” in diameter.
- **Barometric Draft Regulator:** A barometric draft regulator which is the same diameter as the vent pipe must be used, and it should be located close to the heater. See below. Do not install a manual damper or any other device that will obstruct the free flow of the flue gases.

Detailed Requirements for the Vent System (cont'd)

- **Support:** The vent system must be adequately supported using non-combustible strapping or supports to carry the weight of the vent and wind load. Do not use the heater to provide support for the vent system.
- **Vertical Vent:** If installing a factory-built vent, follow the manufacturer's instructions. **If a masonry chimney is used, a thimble that is permanently cemented in place with high temperature cement should be used to permit easy cleaning of the chimney. The end of the vent pipe must not extend past the inside wall of the chimney.**
- **Draft Inducer:** If a draft inducer is used, follow the manufacturer's instructions and wire the inducer according to the wiring diagram provided. See **Optional Draft Inducer Relay** below.
- **Terminal End:** The vent must terminate at least 3 ft (914mm) above the highest point of exit and at least 2 ft (610mm) higher than any portion of a building or obstruction within 10 ft (3M) of the chimney. Install a vent cap on the terminal end of the vent. A Reznor (Option CC1) or Type L Breidert Air-x-hauster® vent cap is recommended. A different style of vent cap could cause nuisance problems.

Draft Regulator

A barometric draft regulator is shipped with this heater and **MUST** be installed in the flue near the heater flue opening.

Refer to the illustration for recommended locations. To install, follow the manufacturer's instructions packaged with the draft regulator.

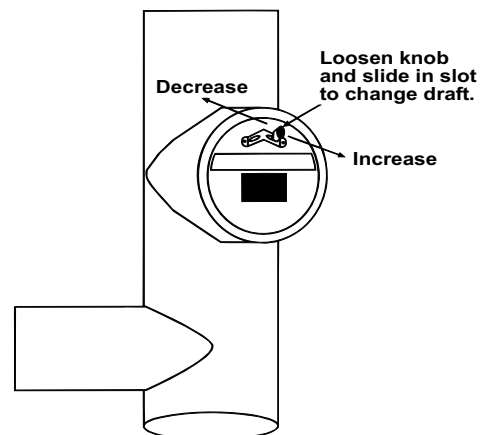

Draft Inducer (Sizes 350 and 500) and Draft Inducer Relay (Size 500)

(NOTE: A field-supplied draft inducer may be required on either a Size 350 or Size 500. To install on a Size 500, a field-supplied relay is required.)

A field-supplied UL or CSA/ULC listed draft inducer is required when the draft in the combustion chamber measures less than .01" w.c. on a draft gauge. Unfortunately, the draft cannot be measured until the heater is operating. A field provided relay may be used to make the necessary electrical connections to operate a draft inducer.

Read the following CAUTION and survey the installation for indications that a draft inducer might be required. A draft inducer may be added at any time, but if a potential need is determined at the time of installation, the easier method is to include the field-supplied draft inducer in the original installation. The draft inducer must be capable of moving at least 450 CFM of flue gas at 500°F.

CAUTION: If there is a backdraft or downdraft, do not continue operation of the heater until the situation is rectified. Equipment and/or property damage could result. Back pressure (backdraft or downdraft) may be caused by the chimney being lower than surrounding objects, such as buildings, hills, trees, rooftops, etc., OR by an exhaust fan in the building. The air intake in the room where the heater is installed must be of sufficient size so there is no change in the draft reading in the flue with the exhaust fan running.

Be sure to measure the draft when all exhaust fans and systems are operating. When a draft inducer is installed, a draft proving switch must be used to shutoff the fuel supply to the burner in the event of failure of the draft inducer. The wiring diagram illustrates the proper wiring of the draft proving switch and the draft booster.

Installing Ducts

Inlet Air Duct

Canadian installations require field installation of an inlet air duct (return air system) on a Model RAD heater. The blower-equipped heater has an inlet air duct flange. Inlet duct dimensions (inside) should be:

	RAD350	RAD500
Height	36" (914mm)	35" (889mm)
Width	54-1/2" (1384mm)	58" (1473mm)

Slip the ductwork over the flange and attach using 1/2" long sheetmetal screws.

Discharge Duct

A discharge duct **may be** attached to a Model RAD heater. To connect the duct to the heater,

- Remove the louvers from the furnace.
- Field fabricate a duct transition as illustrated.
- Attach duct transition to the heater using 1/2" long sheetmetal screws

IMPORTANT: Never reduce the furnace opening size abruptly. Always use a tapered transition like the one illustrated.

RAD	A		B	
	inches	mm	inches	mm
350	54	1372	24-1/4	616
500	57-5/16	1456	20-7/16	519

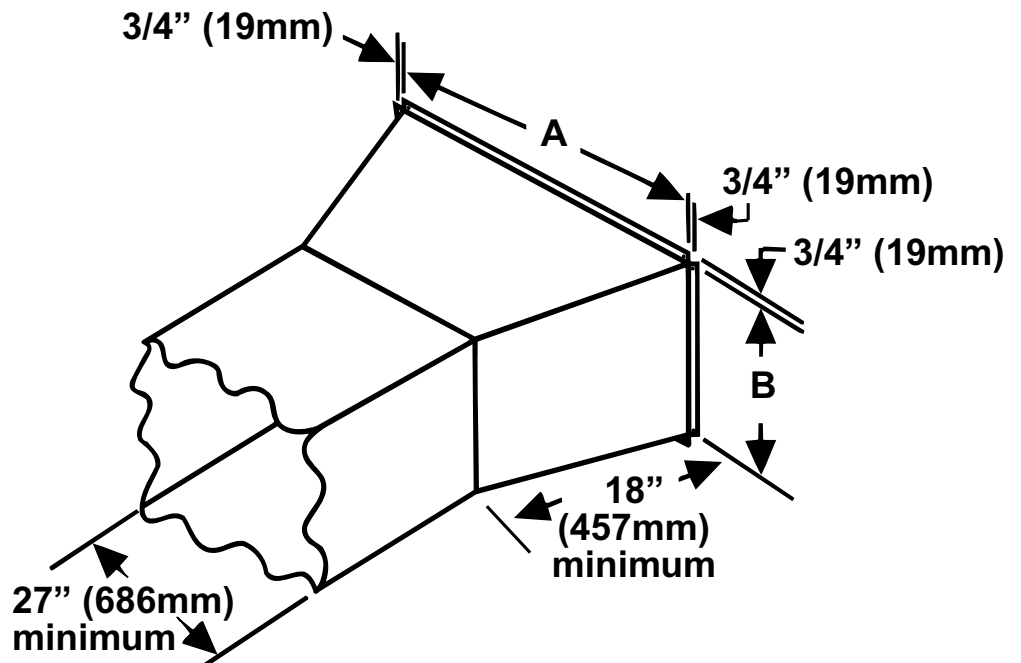

Power Installation

Pump Power

Main Power

NOTE: If servicing a Model RA/RAD500 heater manufactured before 1/2005, refer to wiring diagrams on pages 54-57. Typical wiring diagrams for currently manufactured heaters are on pages 50-53.

DANGER: Make sure that the main circuit is OFF before making any wiring connections. All wiring must be done in accordance with appropriate Codes!

To connect the electrical power **from the heater to the pump**,

- Use a 3 conductor, 14 gauge wire system (RA/RAD 350 - two 115 volt conductors and a ground; RA/RAD 500 - two 230 volt conductors and a ground). Use BX if permitted, but make certain to follow local codes for running conduit.
- Refer to the Field Connection Chart on the wiring diagram for connecting terminals.

To install main power to the system (check the table below and the rating plate on the furnace for current requirements),

- **Models RA/RAD350** - Use #10 gauge stranded copper wire for RA350 and #8 gauge for RAD350 to run a dedicated 115 volt, single phase, line from the power source to a junction box mounted on the wall behind the heater or as required by appropriate codes.
- **Models RA/RAD500** - Use #10 gauge stranded copper wire for RA500 and RAD500 to run a dedicated 230 volt, single phase, 3 wire with ground from the power source to a junction box mounted on the wall behind the heater or as required by appropriate codes.
- Run the appropriate conduit from the heater to the junction box.
- Connect the black wire to L1.
- Connect the red wire to L2.
- Connect the white wire to the neutral lead.
- Connect the green wire to the ground lead.
- Install a fused manual reset, line voltage switch (field supplied) in this main line.
- Electrical Ratings

Model	Total Current Amperes	Minimum Circuit Ampacity	Maximum Fuse Size (Supply)
RA350	23	29	40
RA500	20	26	30
RAD350	34	43	50
RAD500	22	28	35

Heating Thermostat

A 24-volt thermostat is furnished as standard equipment.

DO NOT attempt to wire relays or other accessories to the thermostat connections as these are not load terminals.

DO NOT install on or suspend the thermostat from the heater

DO NOT install thermostat on a cold outside wall

To install the thermostat,

- Locate the thermostat five feet above the floor on an inside wall, not in the path of warm or cold air currents nor in corners where air may be pocketed
- Remove the thermostat cover
- Make sure the heat anticipator dial is set at 0.2 amps
- Connect the wires through the back of the thermostat to the R & W terminals
- Set the ON/OFF switch on the heater electrical box to the "OFF" position and connect the thermostat wires to the two "T" terminals on the ignition controller.

Heater Start-Up

Burner Start-Up System Check

Check Test - Prior to Start-Up

You should check your system completely before operating it.

- Check clearances from combustibles. Be certain that the clearances are in compliance with the appropriate Codes.
- Check hangers and supports. Be certain that all hangers, supports, and arms are adequately anchored and that all unions or threaded fittings are snug and do not rotate. Heater must be level.
- Check to make sure all shipping supports have been removed.
- Check the electrical supply. Be sure that all wire gauges are as recommended and that the supply voltage is as stated on the heater. Determine that fusing or circuit breakers are adequate for the load.
- Check vents. Be sure that vent pipe and chimney meet the requirements and appropriate codes. A UL or CSA/UL listed draft regulator is required. A Reznor® (Option CC1) or Type L Breidert Air-X-hauster® vent cap is recommended. (Type L Air-X-hauster® is a trademark of The G. C. Breidert Company.)
- Check the oil supply. Fill the supply tank to at least six inches from the top of the foot valve. **NOTE:** Always screen used oil with a 70-80 mesh strainer when filling the supply tank.
- Canadian RAD (blower model) installation only -- Be sure an inlet air duct is installed in compliance with Codes.

Priming and Leak Check

For control locations, refer to illustrations on pages 39 and 40.

Priming and Checking the System

The oil supply line to the heater must be full of oil and free of air for proper heater operation.

NOTE: Priming the oil line could take up to 30 minutes depending on the length of the line.

Follow the procedure below to fill the oil line.

1. Be sure the oil tank is filled to at least six inches above the top of the foot valve.
2. Set manual disconnect switch to the ON position.
3. Fill the suction line (line between the supply tank and the pump) with clean used oil.

Priming and Leak Check Continued

For control locations, refer to illustrations on pages 39 and 40.

4. Locate the rubber tubing connecting the pressure switch in the main control box and the compressor.
 - Disconnect the tubing at the fitting on the compressor. This will prevent oil from flowing to the burner.
5. Remove the cad-cell wire from the F1-F2 terminals of the ignition controller.
 - Either attach a piece of tubing to the bleeder valve on the strainer tee on the burner assembly or place a container underneath to collect oil.
 - Loosen the bleeder valve.
6. Set the thermostat to a temperature above room temperature.

NOTE: On initial start-up it will take approximately ten minutes to heat the oil. Once the oil is warm enough, the green light will come on and the unit will be ready to start. This delay only occurs on initial start-up or when the disconnect switch has been turned off for an extended time.

- After the motor starts, place a jumper across the cad-cell terminals (F1-F2) on the ignition controller.
- Observe the remote fuel pump motor to make certain it is running.
- Open the bleeder valve on the remote pump and wait until a full flow of oil is obtained without any air.

IMPORTANT NOTE: If air bubbles are present and do not stop, there is a suction line leak.

- Check the piping between the tank and the pump and correct the leak.
- Once a full flow of oil is present without any sign of air, close the bleeder valve on the remote pump.
- Observe the bleeder valve at the strainer tee and wait until a full flow of oil is obtained without any air.
- Tighten the bleeder valve on the strainer tee and remove the oil container.

NOTE: DO NOT replace the rubber tubing previously disconnected from the compressor and DO NOT reconnect the cad-cell wires.

7. Allow the system to operate for several minutes.
 - Check the system for leaks at all connections.
 - Observe the return line to the tank - oil should be flowing.
 - Correct all leaks and retest the system.
8. When the system checks out as having no leaks, turn disconnect OFF, replace the rubber tubing and cad-cell wires removed earlier.
9. Remove the jumper from the F1-F2 terminals of the ignition controller.

You are now ready to start your system.

Heater Start-Up

Start-Up Procedure

After installing and testing your unit, follow the procedure below to start the system.

- Turn on the main electrical supply to the heater.
- Set the manual disconnect switch to the “ON” position.
- Set the thermostat to a temperature above room temperature.

NOTE: When the low oil temperature limit senses the proper oil temperature, the green light on the burner junction box will come on and the heater will fire.

A 10-minute delay may occur before firing depending on the system and the oil temperature. The delay only occurs on initial start-up or after an electrical power interruption.

If the system does not automatically try to re-light, then the controller is in the “lockout” condition (Sizes 350 and 500 models) and must be reset by depressing the red button on the controller and holding it down for three seconds.

Once the system is purged of all air and oil reaches the nozzle, ignition will occur.

Check Test - After Start-up

Check-Test

Check that there is sufficient draft for proper combustion. A negative draft of .01”-.02” w.c. is required in the combustion chamber over the fire.

NOTE: Draft measurements must be checked anytime there is a change in the air band setting.

RA500

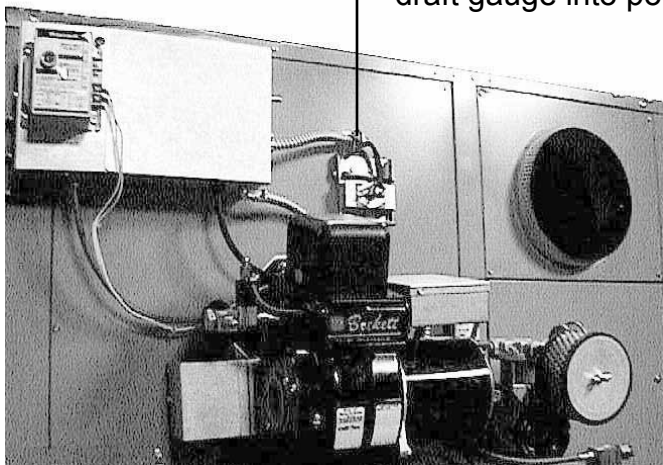

Observation Door
Remove plug on bottom half of door and insert draft gauge into port.

Instructions for Measuring Draft Over Fire:

- Remove the metal plug in the observation door.
- Insert draft gauge (such as Dwyer pressure gauge). Measurement must read at least a negative .01” w.c. to negative .02” w.c.
- If measurement is not as required, adjust draft regulator until measurement is within the proper limits (see page 16).
- Replace the metal plug in the observation door.

Check-Test Continued

WARNING: If there is insufficient draft, it will create a back pressure resulting in oil fumes in the building and/or pulsating when the burner starts and stops. It may cause excess deposits of soot and overheat the heat exchanger resulting in premature failure of the chamber. **THIS TYPE OF FAILURE IS NOT COVERED UNDER THE WARRANTY.**

To correct this problem, the height of the chimney may need increased and/or a UL or CSA/ULC listed draft inducer may be installed.

If a draft inducer is used, a draft proving switch must be installed to shut off the fuel supply to the burner in the event of the failure of the draft inducer.

CAUTION: If there is a backdraft or downdraft, do not continue operation of the heater until the situation is corrected. Equipment and/or property damage could result. Back pressure (backdraft or downdraft) may be caused by the chimney being lower than surrounding objects, such as buildings, hills, trees, rooftops, etc. It may be caused by an exhaust fan in the building. The air intake in the room where the heater is installed must be of sufficient size so that there is no change in the draft reading in the flue with the exhaust fan running.

If there is too much draft, it could cause ignition problems, erratic burner, and loss of thermal efficiency. To correct this problem adjust the barometric damper to reduce the draft.

■ **Check combustion and air band and shutter settings.**

Certain installation conditions may necessitate a change in these settings. We recommend that the need for a change be determined by the use of instruments. When obtaining the CO₂ readings, do so with a hot system that has the correct draft settings. With a clean heat exchanger, these settings should result in Bacharach smoke readings not greater than No. 1 and CO₂ reading in the range listed below.

IMPORTANT: If it is necessary to change the air band settings, the draft measurement must be rechecked.

RAD350

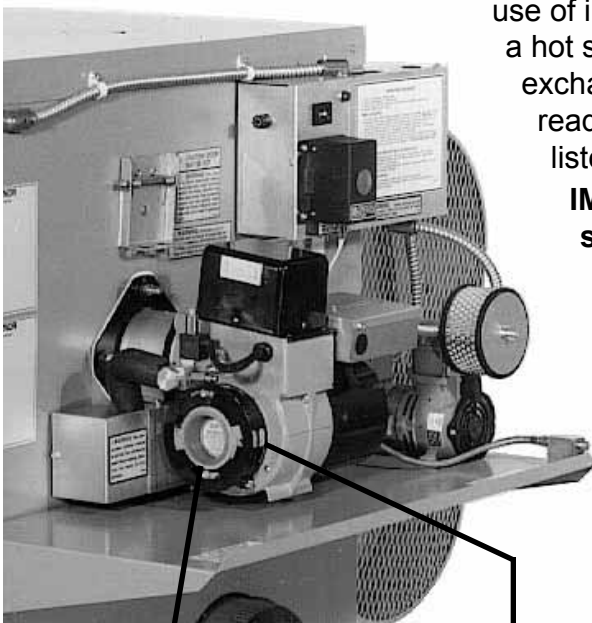

Air Shutter

Air Band

Reference Air Shutter and Air Band Settings				
Size	Elevation (feet)	Air Shutter	Air Band	CO ₂ Range
350	0-3000	#5	#5	10.5 - 11.5%
500	0-3000	#5	#3	11 - 12%
350H	>3000-7000	#4	#2	11.5 - 12.5%
These are settings from which a qualified service-man/installer must make adjustments.				

Check-Test Continued

■ Check Discharge Air Temperature - Model RAD with discharge ductwork only.

RAD350 - This heater is designed for a maximum of .25" w.c. static pressure and for discharge air temperature rises from 40° to 50°F.

RAD500 - The standard heater is designed for a maximum of .25" static pressure and for discharge air temperature rises from 55° to 65°F. A Model RAD with an optional 3HP motor and drive is designed for a maximum of .50" static pressure (check the unit rating plate).

If the heater has been equipped with a duct, the discharge air temperature should be checked.

- Place a thermometer or a thermocouple in the middle of the outlet or at the end of the discharge duct and measure the discharge air temperature after the heater has operated for at least 20 minutes.

If the temperature rise is not within the specified range, the blower speed will have to be adjusted to achieve the correct temperature rise. If the blower motor maximum amp rating is exceeded, the ductwork must be altered to reduce the static pressure (resistance of the air flow).

Follow these instructions to adjust blower speed.

- Turn off the electrical power.
- Loosen belt tension and remove belt.
- On the side of the pulley away from the motor, loosen the set screw.

To increase blower speed, decreasing outlet temperature

- Turn the adjustable half of the pulley inward.

To decrease blower speed, increasing outlet temperature

- Turn the adjustable half of the pulley outward.
One turn of the pulley will change the speed 8-10%.
- Tighten the set screw on the flat portion of the pulley shaft.
- Replace the belt and adjust the belt tension.
Belt tension is adjusted by means of the adjusting screw on the motor base. Adjust until the belt can be depressed 1/2-3/4".
- Tighten the lock nut on the adjusting screw.
- Turn on the electric power.
- Start the heater by turning the thermostat to a setting higher than room temperature.
- Check motor amps with an amp meter. The maximum motor amp rating on the motor nameplate must not be exceeded.
- While the pump is running, record the vacuum gauge reading and post it on or near the remote pump assembly.

The maximum allowable vacuum rise is 10" Hg. (Example: With a new oil filter, if the vacuum gauge indicates a suction line vacuum of 3" Hg, the maximum allowable gauge reading is 13" Hg.)

- Display adhesive "Waste Oil Recycling" decal on entry door or window.
- Adhere tank warning label at location visible when filling the tank or at a point where fuel is first introduced to a transfer piping system.
- Complete the information on page 60. Return all instruction manuals to the "Literature Bag." Give the manuals to the owner to keep for future reference.

CAUTION: An external duct system static pressure not within the limitation on the heater rating plate and/or improper adjustment of the motor pulley or belt may overload the motor or cause overheating of the heat exchanger.

Maintenance

General Maintenance Requirements

Maintenance Schedule

WARNING: Turn off electric power to the unit before doing any service or maintenance on the heater.

When burning used automotive diesel and truck oils, this heater will require more frequent service than conventional heating equipment. All used oils contain a small amount of ash. This ash is similar in texture to that found in wood burning fireplaces, and varies with the types of oil used. **FAILURE TO REMOVE THIS ASH ON A REGULAR BASIS WILL VOID THE WARRANTY.**

Do not let your oil supply tank run out of fuel. Check the oil level in the supply tank daily to be certain an adequate supply is available. Running out of fuel will require you to re-prime the system.

The following are starting points for tailoring a maintenance schedule to fit the application. When performing the maintenance procedures listed below, note the hours on the hour meter (on the remote pump). After one or two cleanings, the maintenance schedule may be altered based on the hours of operation. However, if there is a major change in the type of used oil being burned, maintenance requirements can be affected. Any time there is a major change in fuel, return to the schedule listed below and note the hour meter readings to re-tailor the maintenance schedule.

At the end of the heating season or whenever the heater will be shut down for a long period, always turn off the power. Clean the heat exchanger/combustion chamber and the flue pipe. Before restarting, perform all maintenance checks.

Weekly:

- Check the vacuum gauge on the filter for an indication that the oil line filter needs replaced and/or motor pump screen needs cleaning. The maximum vacuum rise is 10”Hg; the maximum reading is 15”Hg.
- Inspect the combustion chamber and heat exchanger tubes. If cleaning is needed, follow the instructions beginning on page 27. Record the hour meter reading for future reference. A Maintenance Record Chart is provided in the Appendix for this record.

WARNING: Wear protective clothing, including gloves and a face mask or respirator. Dispose of ash properly. See the warning statement on cleaning the combustion chamber.

Monthly:

- Drain water from the bottom of the supply tank until a steady stream of oil is obtained.
- Clean the backflow/ash sensor switch. Remove any soot from the sensor. Check the electrical connections.

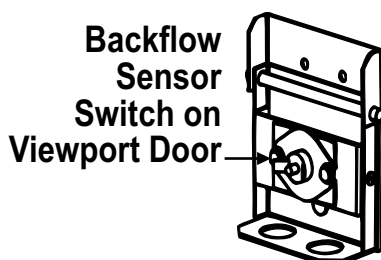

Every Six Months:

- Clean the oil strainer at the burner.
- Clean the foot valve screen.
- Replace the air filter.
- Clean the end cone.
- Replace the oil nozzle.
- Clean the external surfaces of the combustion chamber/heat exchanger.
- Clean the fan or blower.
- Check for oil leaks.
- Check blower belt for tension and wear.
- Inspect the electrodes
- Clean the pre-heater.

NOTE: A maintenance record chart is provided in the Appendix.

Maintenance Procedures

Cleaning the Supply Line Filter and Internal Pump Screen

Cleaning the filter and the pump screen requires breaking the suction line. The suction line is the portion of the supply line from the tank to the remote pump. If air leaks develop in the suction line, the heater will not operate properly.

Follow all instructions, including “recharging the Suction Line,” (page 26) to avoid creating an air leak.

Replacing the Supply Line Filter

1. Remove the old filter canister.

- Carefully unscrew and remove the filter canister. Dispose of properly.

2. Replace the filter canister.

- Attach a replacement filter canister, P/N 176535.

Cleaning the Internal Pump Screen

1. Check the Screen

- Disconnect the inlet oil line from the pump.
- Using a flashlight, look into the pump inlet.
 - a) If the portion of screen visible at the inlet appears to be clogged, go to Step 2.
 - b) If the screen appears unclogged, reconnect the inlet line making sure that the connection is tight. Do not remove the pump cover. Go to the instructions for “Recharging the Suction Line” (below).

2. Remove and Clean the Screen

- To access the screen, the pump cover must be removed.
- Remove the four bolts that hold the pump cover. (Be careful, pump is full of oil).
- Remove the cover being careful not to lose or damage the gasket.
- Remove the circular screen and clean with a solvent and compressed air.

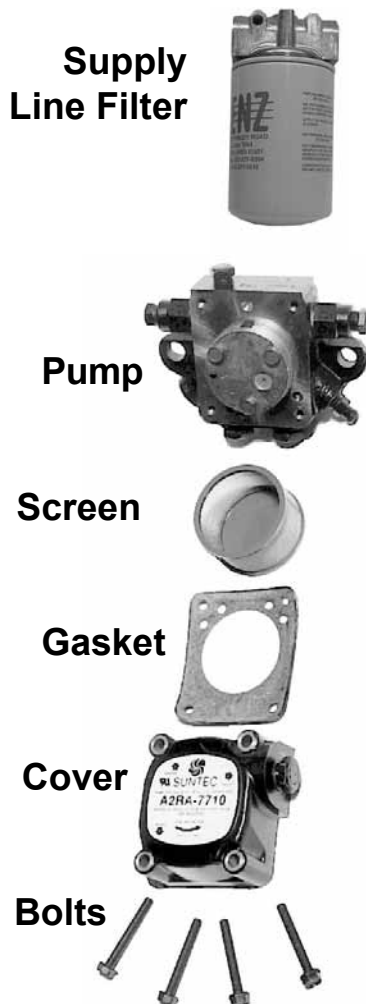

Maintenance Procedures Continued

Cleaning the Internal Pump Screen (cont'd)

NOTE: If the screen is damaged during cleaning, replace it with Reznor P/N 123450.

3. Reassemble the pump

- Check the gasket and if a replacement is needed, replace it with Reznor P/N 123451.
- Re-assemble the pump and reconnect the inlet oil line being sure that the connection is tight.

Recharging the Suction Line

- Remove the fill plug from the inlet manifold and slowly fill the suction line with oil (allow time for air to escape).
- Replace the plug.
- Check vacuum gauge connections and filter housing to be sure that everything is tight. The suction line must be full of oil and all connections tight for the heater to operate properly.

NOTE: Refer to the section, "Priming and Leak check" (starting on page 19) for check list and instructions.

Cleaning the Burner Oil Strainer

Instructions for cleaning the burner oil strainer:

- Identify the strainer tee located in the fuel line just upstream from the burner.
- Remove the hex nut from the end of the strainer tee, being careful not to lose the "O" ring.
- Remove the spring and strainer from the inside of the tee. Clean by washing both the spring and screen with a solvent.
- Reinsert the cleaned screen and spring into the tee. With the "O" ring in place, re-attach the hex nut.



Oil Strainer Tee

Remove Hex Nut, Strainer Screen & Spring



Hex Nut & "O" Ring

Spring



Strainer Screen

Inspecting and Cleaning the Heat Exchanger Tubes, Combustion Chamber, and Flue Pipe

Inspecting Model RA/RAD 350



Turning Box End

NOTE: Prior to 5/02, Size 350 had a two-piece door with a cross support in the middle. The door sections are not hinged and must be completely removed for inspection and service.

WARNING: Used oils may contain engine-wear metal compounds and foreign materials. When burned, these compounds are deposited within or exhausted from this heater. Therefore, care should be taken when using, cleaning and maintaining this equipment.

Whenever any cleaning, including the flue pipe and exhaust stack is done, proper protective equipment, including gloves and a face mask or respirator, must be worn.

WARNING: Turn off electric power before inspecting or cleaning the unit. Allow unit to cool.

Model RA/RAD 350 - To determine need for cleaning, inspect the heat exchanger tubes through the access door on the end of the heater opposite the burner.

- Turn the four outer door latches 1/4 turn.
- Remove the door panel by lifting upward and outward on the door handle.
- Using a 1/2" wrench, remove the nuts and washers from the inner hinged door (See NOTE in the margin). Open door.
- Shine a flashlight into the heat exchanger. As little as 1/16" ash build-up on the internal tube surfaces can dramatically decrease the thermal efficiency of this heater. If the ash build-up is over 1/16", leave the door open and proceed with the cleaning.

NOTE: You cannot adequately make this determination through the flame observation door. The majority of the settlement of ash accumulates in the heat exchanger tubes.

View of an RA/RAD 350 with Hinged Inner Door Open

Combustion Chamber

Button hole type woven ceramic gasket is used between all mating parts.

Inspect Heat Exchanger Tubes



Maintenance Continued

Cleaning Model RA/RAD 350

Model RA/RAD 350 - Removing Soot and Ash from the Combustion Chamber, Heat Exchanger and Flue Pipe

1. On the burner end of the heater, remove the access panel underneath the service tray.

- Pull the door panel straight out from the heater.

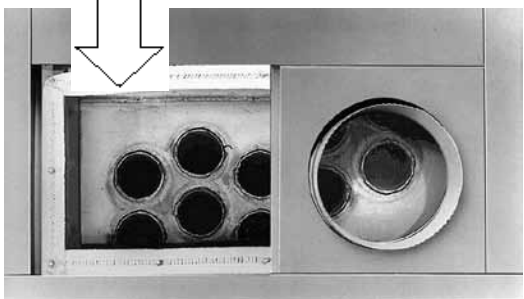
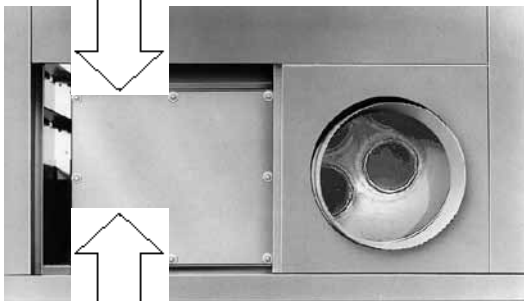
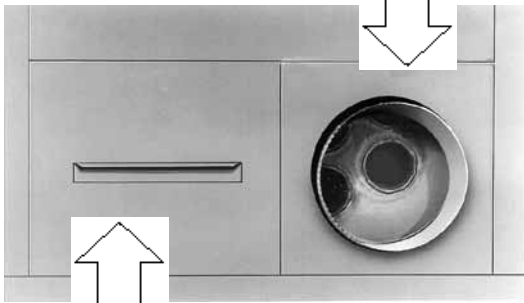
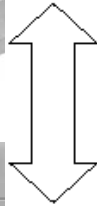
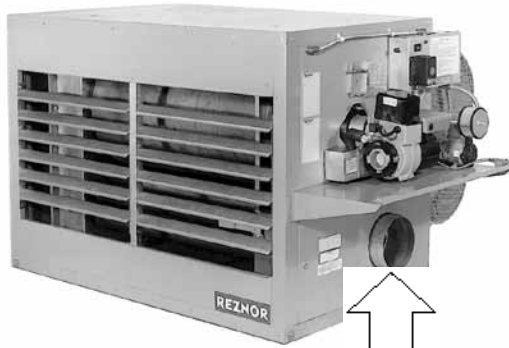

NOTE: Size 350 heaters manufactured prior to October 2004 had single-piece doors the width of the cabinet. On Size 350 heaters with single-piece outer and inner doors, it is necessary to disconnect the flue pipe to remove the door panels. Turn the latches 1/4 turn to remove outer door panel.

2. Remove the inner access panel (exhaust cover).

- Using a 1/2" wrench, remove the nuts and washers from the inner exhaust cover.
- Pull the cover directly off the studs.

3. Clean the combustion chamber and heat exchanger tubes. (Refer to the illustration on page 27.) Clean the flue pipe.

- Use a stiff brush.
- Remove ash from both ends with a shop vacuum.

WARNING: The ash that is removed from this heater may contain heavy metal compounds that are environmentally undesirable and should be disposed of in a conscientious manner.

4. Check Gaskets

- Check all access panel gaskets. If replacement gasket(s) are needed, use gasket identical to the original equipment.

5. Re-assemble

Maintenance Continued

Inspecting Model RA/RAD 500

Model RA/RAD 500 - To determine need for cleaning, inspect the heat exchanger tubes through the smaller access door on the end of the heater opposite the burner (the turning box end).

- Turn the four outer door latches 1/4 turn.
- Remove the door panel by lifting upward and outward on the door handle
- Using a 1/2" wrench, remove the nuts and washers from the left turning box door. Swing open the door.
- Shine a flashlight into the heat exchanger. As little as 1/16" ash build-up on the internal tube surfaces can dramatically decrease the thermal efficiency of this heater. If the ash build-up is over 1/16", proceed with the cleaning.

NOTE: You cannot adequately make this determination through the flame observation door. The majority of the settlement of ash accumulates in the heat exchanger tubes.

Remove smaller access panel to inspect heat exchanger tubes.

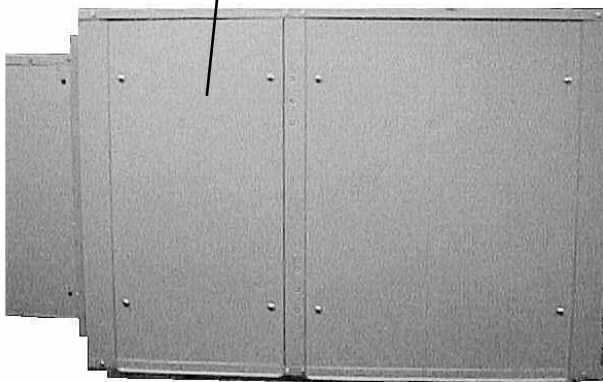

View with Outer Doors Removed

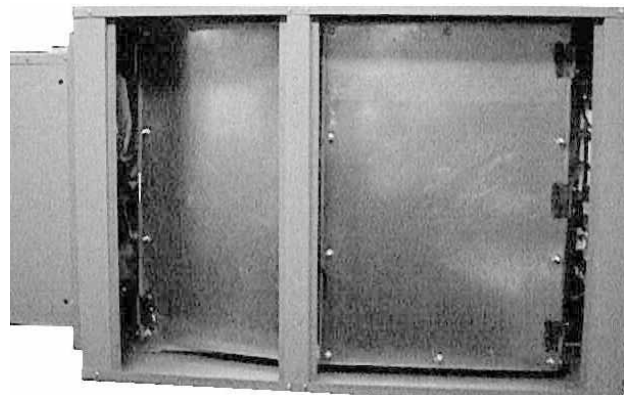

View with Both Hinged Turning Box Doors Open

Inspect Heat Exchanger Tubes

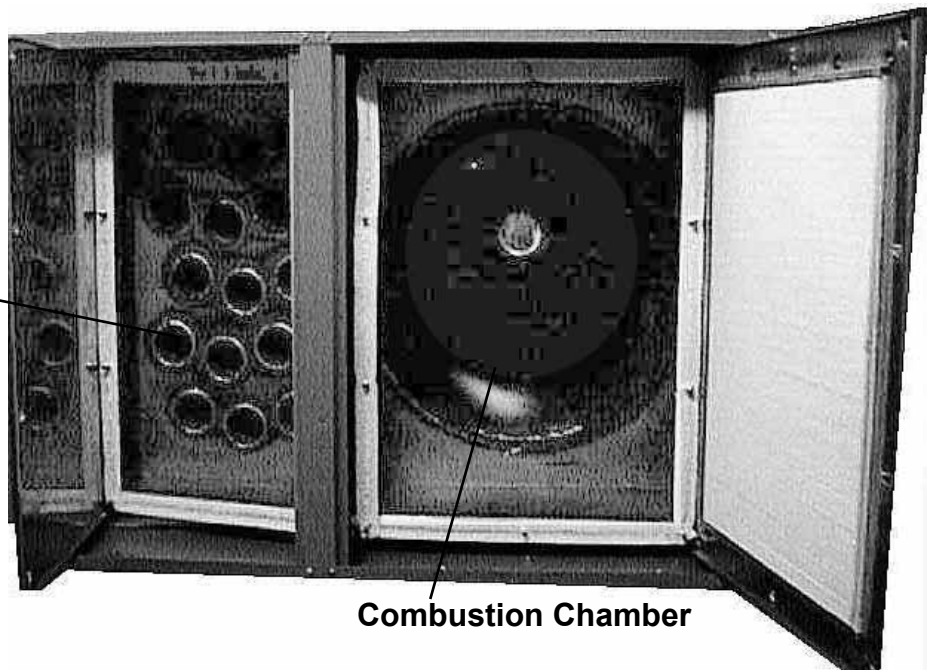

Combustion Chamber

Cleaning Model RA/RAD 500

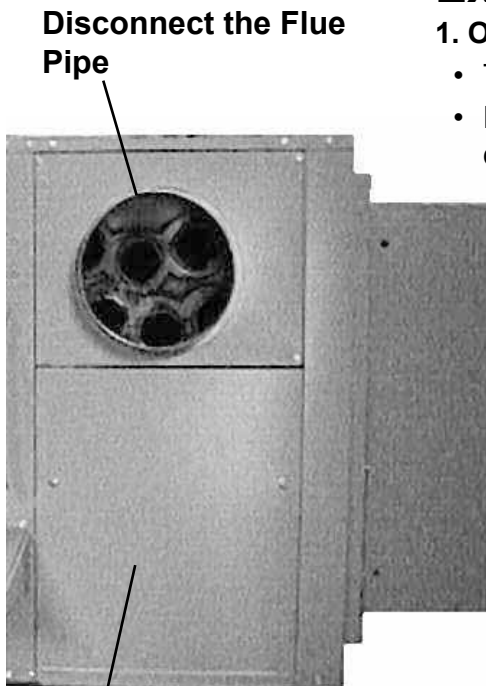

Disconnect the Flue
Pipe

Remove the Outer
and Inner Access
Panels

Model RA/RAD 500 - Removing Soot and Ash from the Combustion Chamber, Heat Exchanger, and Flue Pipe

1. Open the doors on the turning box end.

- Turn the outer door latches 1/4 turn.
- Remove the door panels by lifting upward and outward on the door handle
 - Using a 1/2" wrench, remove the nuts and washers from the inner doors.
 - Swing the doors open.

2. Open the access panel located beside the service tray.

- Turn the outer door latches 1/4 turn.
- Pull the panel up and out from the heater.
- Using a 1/2" wrench, remove the nuts and washers from the inner access panel.
- Pull the cover directly off the studs.

3. Disconnect the flue pipe from the flue collar.

4. Clean the combustion chamber (page 29), heat exchanger tubes, and the flue pipe.

- Use a stiff brush.
- Remove ash with a shop vacuum.

WARNING: The ash that is removed from this heater may contain heavy metal compounds that are environmentally undesirable and should be disposed of in a conscientious manner.

5. Check Gaskets

- Check all access panel gaskets. If replacement gasket(s) are needed, use gaskets identical to the original equipment.

6. Re-assemble

Replacing the Compressed Air Filter

Locate the compressed air filter.

- Remove the wing nut, the cover plate, and the filter.
- Properly discard the old filter and replace with a new filter (Reznor P/N 107216, Wix Filter No. 43274, or NAPA No. 2374).
- Fasten with cover and wing nut.

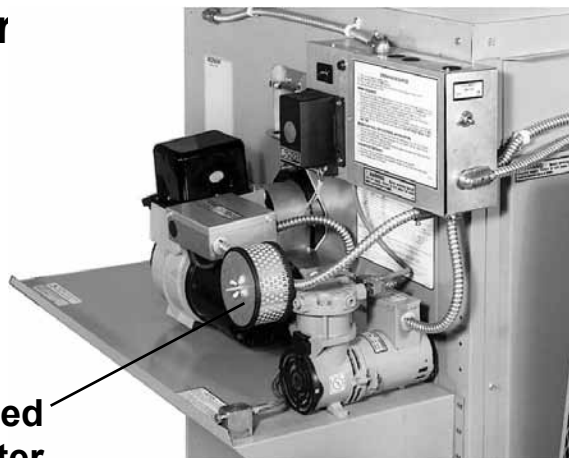

Compressed
Air Filter

Maintenance Procedures Continued

Removing Burner and Cleaning End Cone, Nozzle, and Electrodes

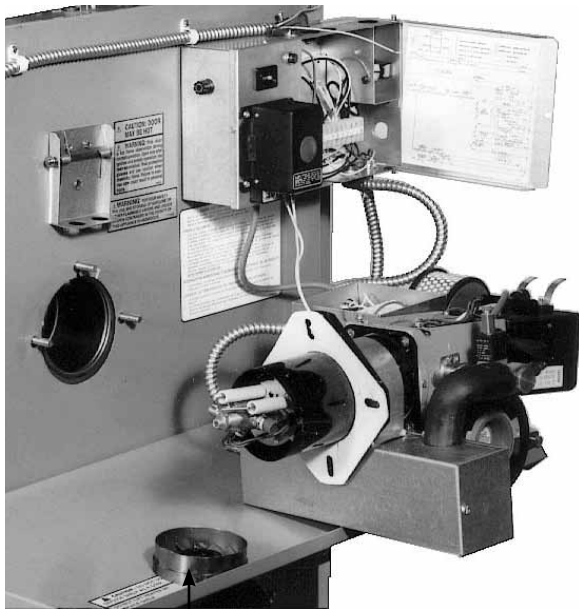

End Cone Removed

WARNING: Turn off the electric power before burner is removed for service.

To gain access to the end cone, the burner must be removed.

1. To Remove Burner

- Locate the two yellow wires that go from the burner to the ignition controller.
- Disconnect these wires at the terminals on the ignition controller.
- Remove the three nuts and washers that retain the burner to the heater.

- Slide the burner off the bolts and rotate as illustrated.

2. To Remove/Clean the End Cone

- Remove the screws that hold the end cone to the burner tube.
- Remove and clean the end cone using a stiff wire brush.
- Check the end cone for deterioration and replace if deterioration exists.

3. To Remove the Nozzle (requires both a 1" and a 5/8" open-end wrench)

- To prevent the fuel line assembly from twisting, use a 1" open-end wrench to hold the nozzle adapter while removing the nozzle with a 5/8" open-end wrench.
- Clean nozzle by disassembling, washing thoroughly, and blowing dry with compressed air.
- If nozzle face appears worn, replace the oil nozzle. For Models RA/RAD350, use replacement oil nozzle

P/N 129382; for Models RA/RAD500, use replacement oil nozzle P/N 157041. Annual nozzle replacement is recommended. This nozzle is custom designed. **Do not substitute nozzle.**

- Replace the end cone.

NOTE: Be sure NOT to damage the "O" ring on the nozzle. If the "O" ring appears damaged, replace the nozzle.

4. Inspect the Electrodes

- The electrode porcelain insulators must be free from carbon, oil, dirt, pinhole leaks, cracks, moisture and evidence of over-the-surface arc tracking. Otherwise, short circuiting could cause ignition problems. If any of these conditions exist, replace with new porcelain insulators (Replacement kit P/N 269820).
- If a need for service or replacement is determined, see instructions on page 32.

5. Reassemble

- Check the gasket. If in tact, position it over the studs. If damaged, replace with like replacement.
- Line the burner up with the studs and slide the tube into the heater.
- Using the nuts and washers, attach the burner mounting flange.
- Re-connect the yellow wires to the ignition controller.

Removing Fuel Line Assembly to Service Controls and Spark Electrodes (Alternate method for servicing nozzle)

WARNING: Turn off the electric power before removing the fuel line assembly.

NOTE: In order to service the fuel line assembly controls and spark electrodes, it is necessary to remove the fuel line assembly.

Removing the Fuel Line Assembly

1. Loosen the connection nut one or two turns.
2. Disconnect the fuel connection assembly by loosening the 5/16" inverted flare fitting. Do not change the position of the escutcheon plate.
 - Pull the fuel connection assembly clear of the burner housing.
3. Loosen the two transformer hold-down screws.
 - Lift the hinged transformer to its open position.
4. There are eight wires in the fuel line assembly wire bundle.
 - Mark and disconnect the wires from their terminals in the burner junction box.
5. Disconnect the nozzle air hose from the fitting at the air compressor.
 - Pull the hose through the opening "into" the burner housing.
6. The fuel line assembly may now be removed by either
 - Pulling the assembly up slightly and toward the rear of the burner housing.
 - OR removing the burner and end cone and pulling straight out of the blast tube. See page 31 for details.

Servicing/Replacing Spark Electrodes

To service or replace the Spark Electrodes

Remove any carbon formation on the spark electrodes.

- Check the electrodes for deterioration and the insulators for cracks or damage.
 - Replace the electrode assemblies with kit P/N 269820 if any damage or deterioration exists.
 - After service or replacement, check the position of the electrodes.
 - Adjust the electrode location precisely.



Escutcheon Plate

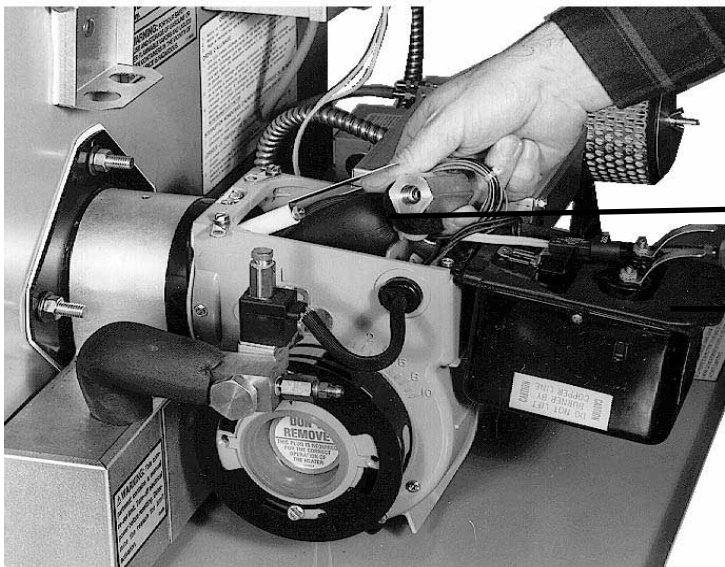

Fuel Line Assembly Removed

Maintenance Procedures Continued

Electrode Adjustment

Check the placement of the electrodes according to the illustration below. If adjustments are required, loosen the 1/4" screw. Make adjustments in the order listed below. Recheck, and if necessary, re-adjust until electrodes are in proper position.

- 1) From center of nozzle orifice to electrode - up 5/16"
- 2) Electrode Gap (distance between electrodes - 1/8"
- 3) Relationship of the end of the electrodes to the tip of the nozzle - 1/8" ahead
- 4) Relationship of the tip of the nozzle to the inside radius of the end cone -- Flush to 1/16" ahead - NEVER BEHIND

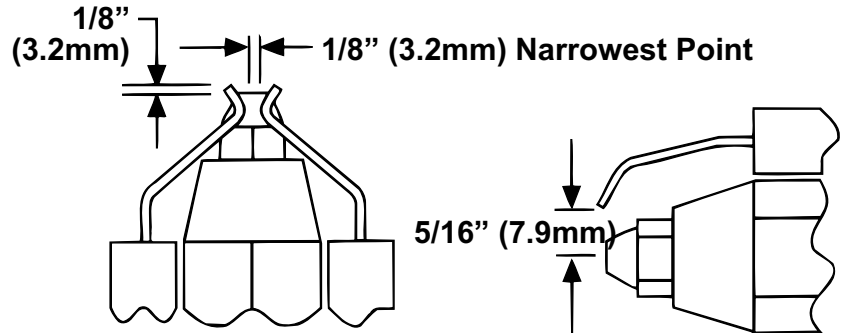

Reassembling the Fuel Line Assembly

1. To reassemble the Fuel Line Assembly
 - Slide the fuel line assembly into the burner housing and the burner tube.
2. Connect the fuel connection assembly to the fuel line assembly.
 - Tighten the 5/16" inverted flare nut firmly. Then tighten the connection nut. Do not move the escutcheon plate.
 - Check the spacing between the oil nozzle and the end cone. Refer to Electrode Adjustment above.
3. Connect the eight wires in the fuel line assembly wiring bundle. Refer to the wiring diagram in the Appendix of this manual or the wiring diagram on the heater.
4. Push the air line hose out through the burner housing and reconnect it to the air compressor.
5. Close the spark transformer cover and attach with the two screws. Be certain transformer clips make contact with the electrodes.

NOTE: Once assembly is in place, verify that the nozzle, end cone, and electrodes are correctly located.

Cleaning Oil Pre-Heater System

WARNING: Turn off the electric power and allow the pre-heater to cool before servicing.

1. Remove the Burner
 - Locate the two yellow wires that go from the burner to the ignition controller. Disconnect these wires at the terminals on the ignition controller.
 - Remove the three nuts and washers that retain the burner to the heater. Slide the burner off the bolts and rotate.

Maintenance Procedures Continued

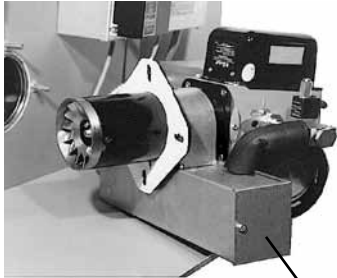

Pre-Heater Box



Pre-Heater Controls

2. Remove the Pre-Heater from the Pre-Heater Box

- Remove the corner panel from the end of the box. The pre-heater controls are visible.
- Disconnect the fuel lines at the inlet and outlet connections. NOTE: There will be oil in the lines.
- Disconnect wires to the temperature controls.
- Disconnect the heating element wires.
- Remove the screw that attaches the pre-heater front support to the bottom of the box.
- Slide the cylindrical aluminium pre-heater out of the box.

3. Clean the Pre-heater

- Place the pre-heater in a vice and carefully remove the outer cylinder and the “O” ring. NOTE: There will be oil in the pre-heater.
- Clean the inner section with a cloth and degreaser such as carburetor cleaner. Be careful not to “clean” the electrical controls. Do not immerse in cleaning fluid.
- Clean the outer portion of the cylinder with degreaser.



4. Reassemble the Pre-Heater and the heater.

- Check the “O” ring. If a new one is required, replace with P/N 132224.
- Reassemble the cylinder pieces with “O” ring in place.
- Slide the pre-heater in the box and attach the front support. Reconnect the wires and the fuel lines and close the corner cover.
- Replace the burner assembly and reconnect the ignition controller.

To gain access to the front side of the combustion chamber/heat exchanger, remove the discharge louvers.

To access the air moving device, disconnect the wiring in the fan/blower junction box and the flexible conduit.

- Use a stiff brush and a shop vacuum to clean the accumulated dust and dirt from the exterior surface of the combustion chamber and the heat exchanger.
- Clean the air moving device (fan or blower). Use a brush and a shop vacuum, being careful not to bend or damage either the fan blade or the blower wheel. Use a shop vacuum to remove accumulated dirt from the motor.
- Replace the air moving device and the discharge louvers.
- Connect the flexible conduit and wiring.

Check operation.

Cleaning ensures maximum efficiency and eliminates the possibility of the heater cycling on the limit switch from lack of air flow.

Cleaning Exterior Surfaces of Combustion Chamber, Heat Exchanger and Air Moving Device

WARNING: Turn off the electric power before cleaning heater.

Service

General Service

Reznor® used-oil-fired heaters have been designed and manufactured to provide years of trouble free operation.

However, as with any type of mechanical equipment, it can malfunction. For your safety, we suggest that if you are unfamiliar with servicing this type of equipment, contact a qualified service person. The material contained in this section is prepared to aid an experienced service person in diagnosing and repairing Reznor Model RA/RAD used-oil-fired heaters.

General Operation

How a Reznor® Model RA/RAD Used-Oil-Fired Heater Operates

When service is necessary, it is always helpful to understand the operation of the device being serviced. With this in mind, the following information has been prepared. Because of the many unique features of the heater, we as the designer and manufacturer believe that it will be worth your time to read this information before beginning any service function.

The RA/RAD heaters differ from most residential and commercial oil furnaces and used oil heaters in that the oil pump meters the volume of oil supplied to the burner. A constant volume of oil is delivered by the pump to the burner regardless of the oil viscosity. Oil pressure at the outlet of the pump will vary depending upon oil grade, the length and height of the supply line, and the oil temperature.

If a pressure in excess of 50 psi is experienced at the pump, a relief valve will open and return the oil to the supply tank.

Oil pressure at the atomizing nozzle will vary from .25 psi to 4 psi depending on the type of oil being burned. Nozzle oil pressure is not critical because compressed air is used to atomize the oil.

The solenoid valve located adjacent to the burner housing performs two tasks. The primary task is to prevent oil from flowing into the combustion chamber due to oil expansion in the heater. The second task is to assist in preventing oil from flowing backwards. Both the solenoid valve and the pump motor are turned on and off by the ignition controller. The check valve at the pump prevents backwards flow of oil in both the heater supply line and the suction line to the pump.

To properly atomize the different types of used oil, the oil must be heated. The oil flows through an aluminum heat exchanger (pre-heater) with either a 650 watt (RA/RAD350) or a 770 watt (RA/RAD500) heating element. This oil heater which is external to the burner preheats the oil to approximately 175°F. A pair of 30 watt heating elements on the fuel line and nozzle assembly within the burner maintain an oil atomizing temperature of 160°F. Temperature sensors prevent burner operation until the proper temperatures are attained. Oil temperature is maintained continuously as long as the electrical power is on to the heater.

General Operation Continued

Compressed air for atomizing the used oil is supplied by a piston-type compressor mounted on the service tray. Model RA/RAD 350 heaters require air pressure within a 12 to 15 psi range for proper oil atomization. Model RA/RAD 500 heaters require air pressure within a 12 to 16 psi range for proper oil atomization. To assure that the correct atomizing air pressure is available, a pressure switch permits oil flow to the nozzle only when a minimum of 12 psi is sensed.

Combustion air is supplied by a blower contained in the burner housing. An adjustable air shutter and air band located on the outside of the burner housing control the quantity of combustion air. Both are preset at the factory and should be changed only if the CO₂ measurement indicates the need to do so. See Check-Test-Start, for factory settings and instructions for measuring CO₂.

Ignition of the atomized oil and combustion air mixture is accomplished by a high voltage spark across the two electrodes located near the atomizing nozzle. Ignition of the oil is detected by a cadmium sulfide flame sensor. Light produced by the flame lowers the electrical resistance of the cad cell. This change is sensed by the ignition controller which allows a continued flow of oil and shuts off the spark transformer after a 30-second trial-for-ignition period.

If for some reason, ignition does not occur or the flame goes out during the trial period, the primary control will lockout. To restart, the safety switch must be manually reset by pushing the red reset button on the ignition control module. Depress and hold the reset button for three seconds. If the heater does not ignite, contact your service person.

If the instructions in this manual are followed, excessive amounts of unburned oil will not accumulate inside the combustion chamber. If the caution statement about resetting the controller more than one time is not heeded, then unburned oil will accumulate in the combustion chamber. **If unburned oil accumulates, DO NOT** attempt to fire the heater and burn off the oil. Remove the combustion chamber access panels as described in Maintenance Section, "Inspecting and Removing Soot and Ash from the Combustion Chamber/Heat Exchanger". Wipe out any accumulated oil with cloth rags. Properly dispose of the rags.

CAUTION: Do not reset the primary control more than one time. If the heater does not ignite, contact your service person.

If the flame fails during normal operation, the heater will go into lockout requiring manual reset of the primary controller. Depress and hold the reset button for three seconds. If the heater does not ignite, contact your service person.

If power fails, the heater will shut down and normal trial for ignition will begin on call for heat when the power is restored.

Approximately 1-1/2 to 2 minutes after the thermostat calls for heat and ignition is established, the circulating fans or blowers will come on. The circulating airflow will continue about three minutes after the burner shuts down.

Troubleshooting

Oil Burner Troubleshooting

To diagnose malfunctions properly, the following test equipment is required:

- 1) An electrical test meter that can measure AC volts, ohms, and amps;
- 2) A combustion analyzer kit to measure oxygen and/or carbon dioxide, smoke, stack temperature, and draft; and
- 3) Two pressure gauges with scales of 0-100 PSIG and 0-30 PSIG.

Before test firing any heater, check the combustion chamber for an excessive accumulation of unburned oil and restore to safe condition before firing.

WARNING: Do not attempt to start the burner when excess oil has accumulated, when the furnace is full of vapor, or when the combustion chamber is very hot.

NOTE: Refer to the troubleshooting guide on page 38 to select the appropriate troubleshooting chart.

Check the Indicator Lights

Light	Location (on the Electrical Box)	Function
GREEN	On the side next to disconnect (on/off) switch	Indicates that the main power is on to the heater
GREEN	On the fixed-cover portion above the ignition controller	Indicates that all limits have been satisfied and the unit is ready to operate

Backflow Sensor Switch

Viewport Cover

Manually Reset Backflow Sensor Switch

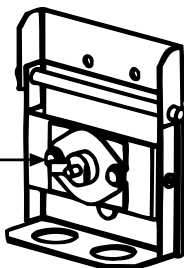

Description/Application - The backflow sensor is a temperature-sensitive switch that is designed to shutdown the heater when there is a positive pressure in the combustion chamber. The heater is designed to operate with an overfire draft of -0.01" to -0.02" w.c. Prolonged operation at a positive pressure (equal to or greater than 0.00" w.c.) can cause overheating and accidental component failure. Undesirable positive furnace pressure can be caused by any one or a combination of the following conditions:

- Totally or partially blocked flue gas venting system
- Improperly designed venting system
- Improper fuel-to-air ratio for combustion
- Excessive ash buildup on interior heat exchanger surfaces
- Blocked heat exchanger passages
- Improper atomization of the fuel
- Plugged or defective fuel nozzle
- Improperly adjusted fuel nozzle assembly
- Burning off-specification fuel
- Changes in outside ambient temperature

Troubleshooting Continued

Location - The backflow sensor switch is mounted on a bracket on the hinged viewport cover on the control side of the heater. The location is important in the operation of this switch. Except for limited observation, the viewport cover must be kept closed for the sensor (and heater) to operate properly.

Operation - Underneath the sensor bracket, the viewport cover has a 3/8" diameter hole. Under normal negative overfire operating conditions, room air is constantly drawn into that small opening. The temperature-sensitive backflow sensor is "cooled" by the air flow. If for any of the reasons listed, the furnace pressure becomes zero, or slightly positive, the flow of air decreases. If this condition persists (10 minutes maximum) the "uncooled" backflow sensor activates interrupting power to the ignition controller. The green limit status light will go out, and the heater goes through the normal post purge and cool down cycle.

After the problem has been determined and corrected, push the manual reset button on the backflow sensor, and follow the instructions to relight the heater. Check for proper operation.

Maintenance - A thin film of soot will form on the face of the backflow sensor. At least once a month and during any routine heater cleaning, open the viewport cover and clean the soot from the sensor. Check the wire connections during scheduled maintenance inspections.

Troubleshooting Chart Guide

Symptoms Follow Troubleshooting Chart

With thermostat calling for heat, burner motor never attempts to run (Green "power on" light is lit; Green "system ready" light is not lit). **Chart No. 1, page 41**

Chart 1 check completed, but burner motor never attempts to run.

With thermostat calling for heat, burner motor runs momentarily. **Chart No. 2, page 42**

System does not attempt to ignite. **Chart No. 3, page 43**

Burner ignites and burns steadily until system goes into lockout. **Chart No. 4, page 44**

Burner operation erratic/unstable flame pattern. **Chart No. 5, page 45**

High temperature limit cycles. **Chart No. 6, page 45**

Oil delivery system troubleshooting. **Chart No. 7, page 47**

CAUTION: The items on the Troubleshooting Charts that are marked with an asterisk represent events that have occurred due to the improper functioning of the heater. It is necessary to observe the operation of the heater to determine what caused these events to occur.

Location of Components Referenced in Troubleshooting Charts

Size 350

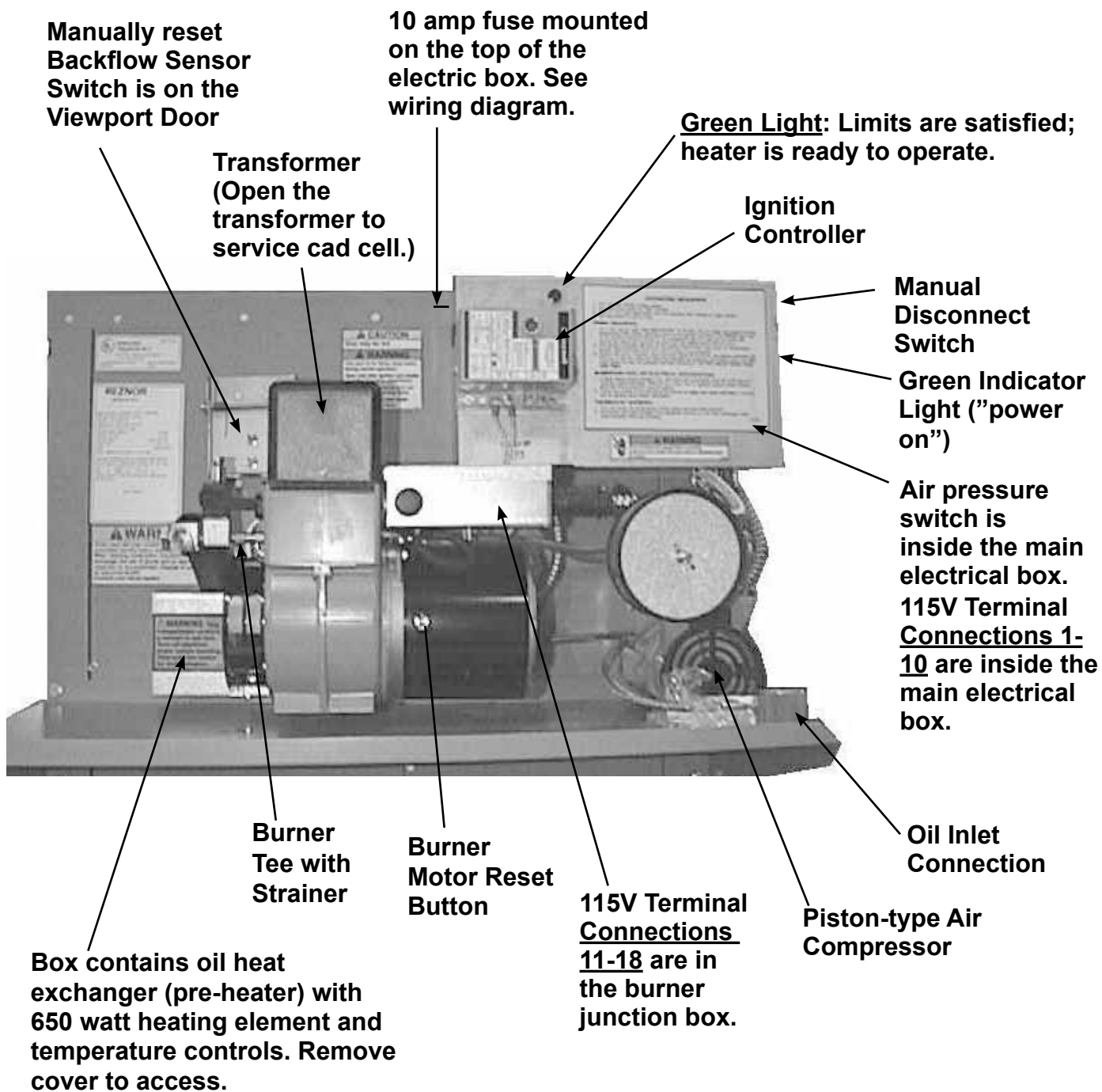

Location of Components Referenced in Troubleshooting Charts

Size 500

IMPORTANT NOTE: Effective 1/20/2005, Models RA/RAD 500 were converted to a 240 volt 3-wire system. The cartridge heaters, air compressor, burner, and hour meter were changed from 240 volt to 120 volt.

Where applicable, troubleshooting charts have alternate instructions for a Size 500 manufactured prior to 1/2005. Before troubleshooting, check the wiring diagram on the heater against the Size 500 diagrams on pages 50-57 to verify which instructions apply to the unit being serviced.

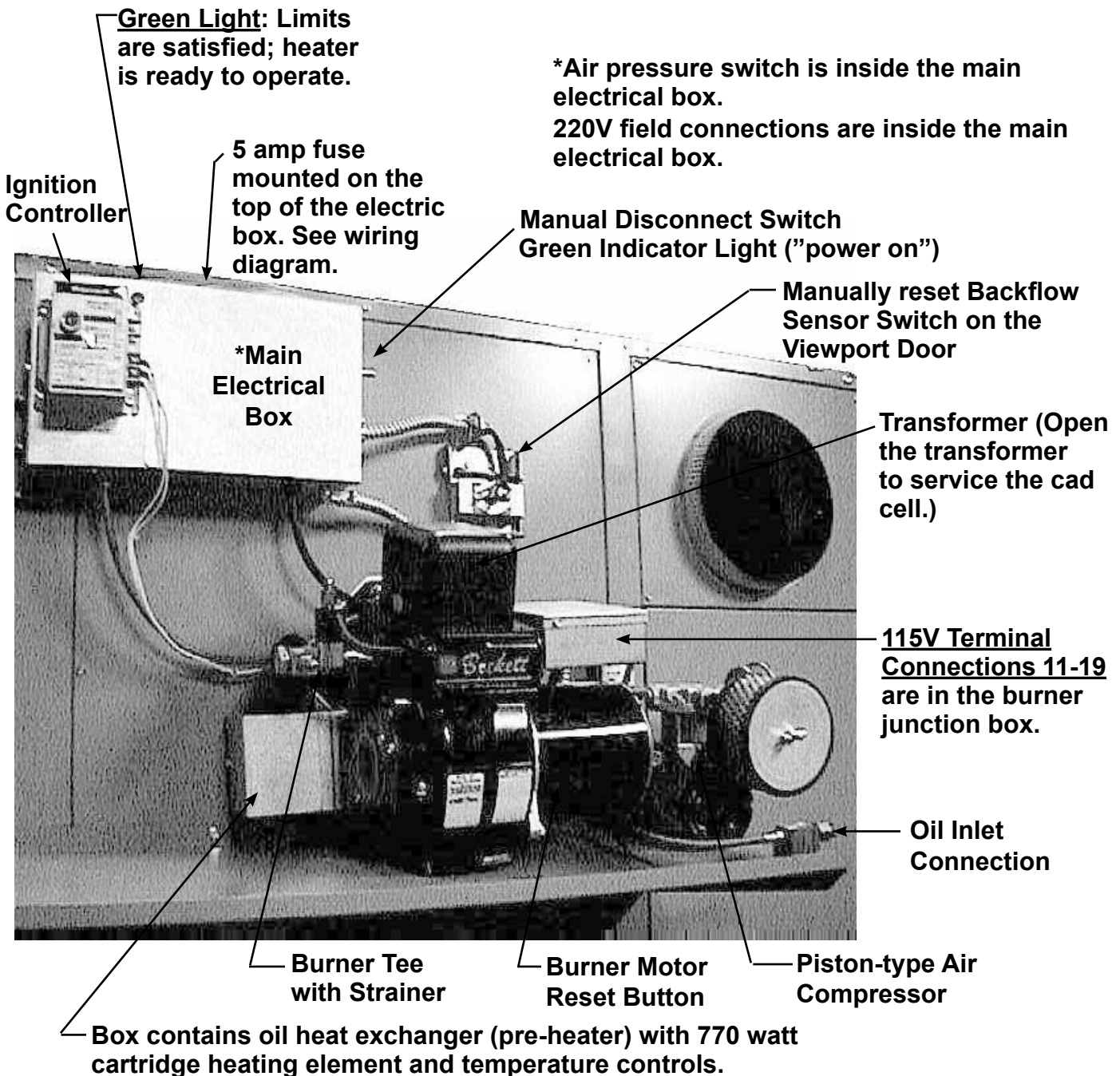

Troubleshooting Continued

Chart No. 1 - Thermostat calling for heat; Burner motor never attempts to run.

Refer to illustrations on page 39 or 40 and 42.

FIRST, turn on the main power to the unit at the disconnect switch and wait at least 15 minutes before proceeding.

- If GREEN "system ready" light is NOT LIT, continue with the troubleshooting guide in Chart No. 1, left.
- If GREEN "system ready" light is "ON" skip to Chart No. 2, page 42.

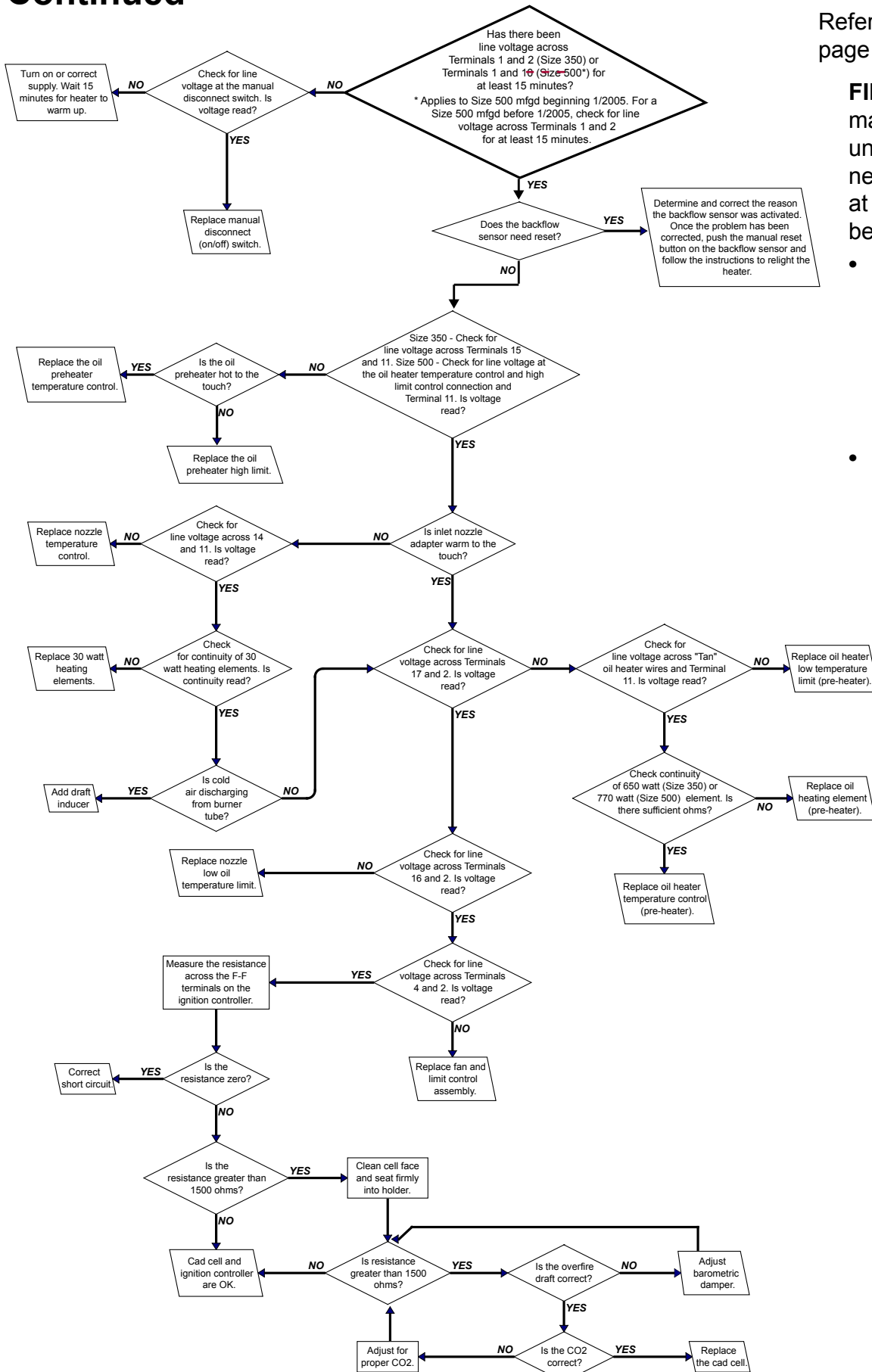

Troubleshooting Continued

Oil Heat Exchanger and Fuel Line Assembly Reference Chart No. 1, page 41

Locations and Replacement Instructions for Heating Element and Temperature Controls on Oil Pre-heat Heat Exchanger

Refer to illustrations on pages 39-40.

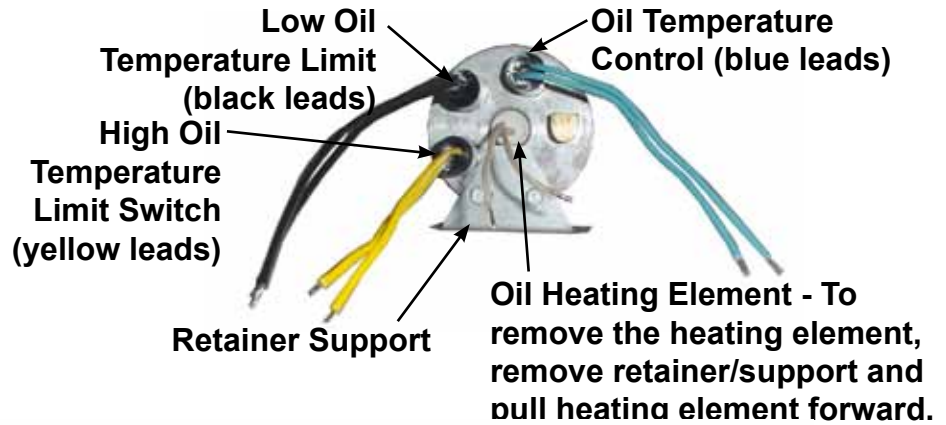

Locations and Replacement Instructions for the Two 30 Watt Heating Elements in the Fuel Line Assembly

Inlet Heater

Remove the silicone rubber to free heating element (30 watt). When replacing, use silicone rubber to retain the new element.

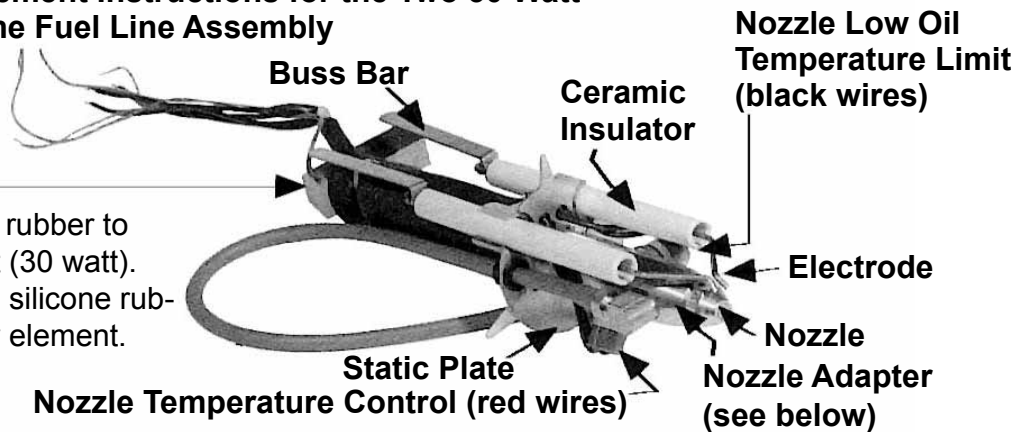

The **nozzle adapter** also contains a 30 watt heating element. To replace the element: **1)** Remove the buss bars and **2)** unscrew the inlet heater and slide the black insulation rearward. Loosen set screw which holds the static plate and slide rearward. This will expose the heating element.

Chart No. 2 - Thermostat calling for heat, burner motor never attempts to run (green light is lit) indicating "System Ready". Chart No. 1 has been successfully completed.

NOTE: After ignition control is reset, you will have 30 SECONDS to perform the tests shown below before the controller locks out.

Reset ignition control: Press the **BUTTON**, hold for four seconds, and release. **DO NOT RESET MORE THAN ONE TIME.**

*Reset button on the motor activates when the motor is overheated. Motor amp draw must be less than the full load amps on the motor rating plate. Verify the motor is operating correctly.

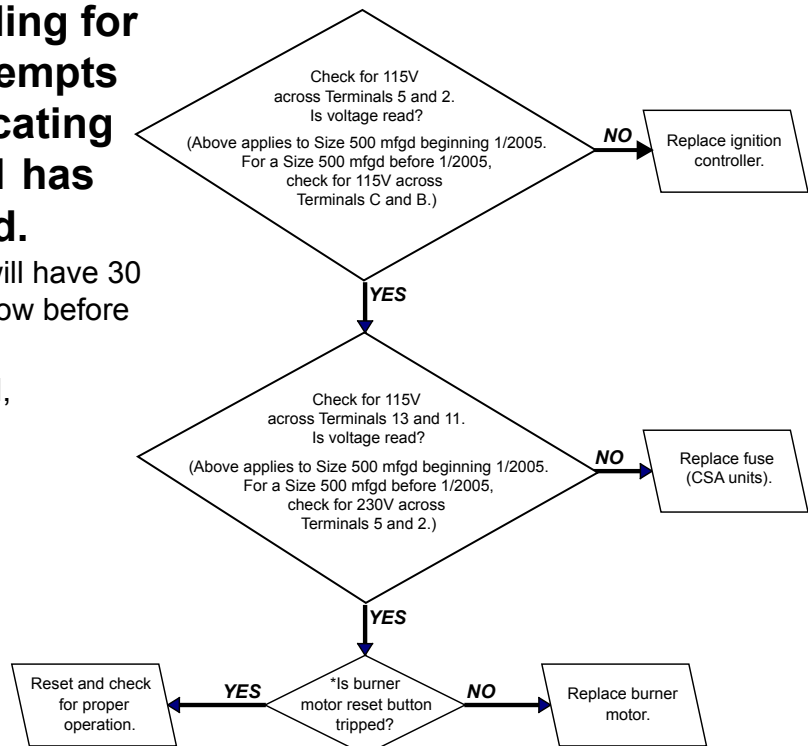
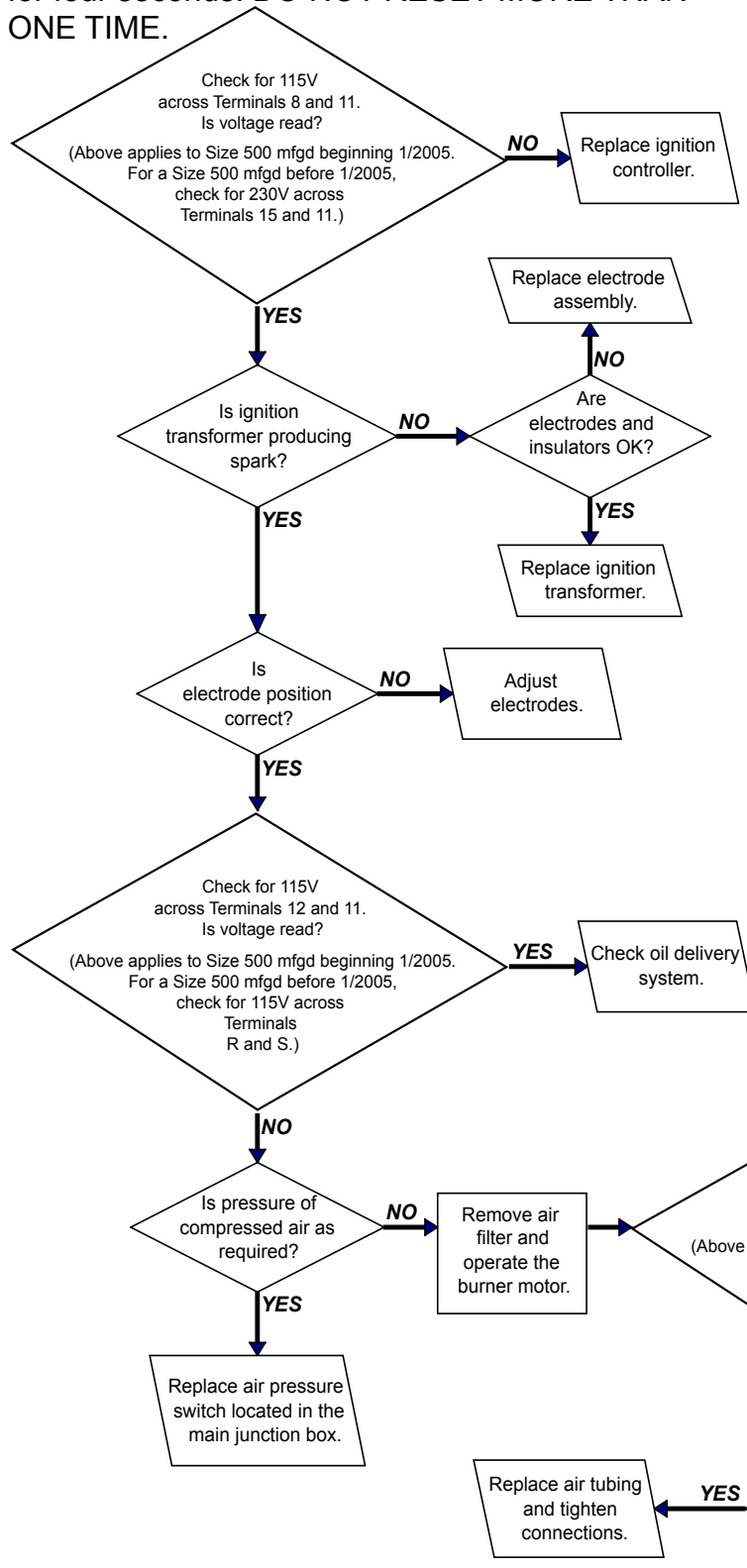

Chart No. 3 - Thermostat is calling for heat. Burner motor runs for about 30-45 seconds. System does not attempt to ignite.

First, check combustion chamber for excess oil.

NOTE: After ignition control is reset, you will have 30 SECONDS to perform the tests shown below before the controller locks out.

Reset ignition control: Press the **BUTTON** and hold for four seconds. **DO NOT RESET MORE THAN ONE TIME.**



Transformer and Electrode Checks:

Measure voltage between transformer/primary lead and neutral connection. Check transformer, insulators, and electrodes.

The secondary terminals of a good transformer deliver 5000 volts arc to ground, for a total of 10,000 volts between terminals. Measure this with a transformer tester or use a well insulated screwdriver to draw an arc across the two springs. This should be at least 3/4" in length. Check each secondary output terminal by drawing a strong arc between the spring and base. If the arc is erratic, weak, or unbalanced between the two terminals, replace the transformer. Replace electrodes when the tips become worn or eroded.

Replace any insulators that are questionable. Transformer failures and ignition problem can be caused by the following:

- **Excessive gap on the ignition electrodes. Gap should be 3/32".**
- **High ambient temperatures**
- **High humidity**
- **Carbon residue on the porcelain bushings**
- **Low input line voltage**
- **Arcing between the ignition electrodes and the transformer springs. They must have good contact.**
- **Carbon residue, moisture, crazing or pin holes on the insulators**
- **Improper positioning of nozzle in relation to the radius of the end cone**
- **Carbon residue on electrode parts**

Troubleshooting Continued

Chart No. 4 - Burner ignites and burns steadily until the system goes into lockout.

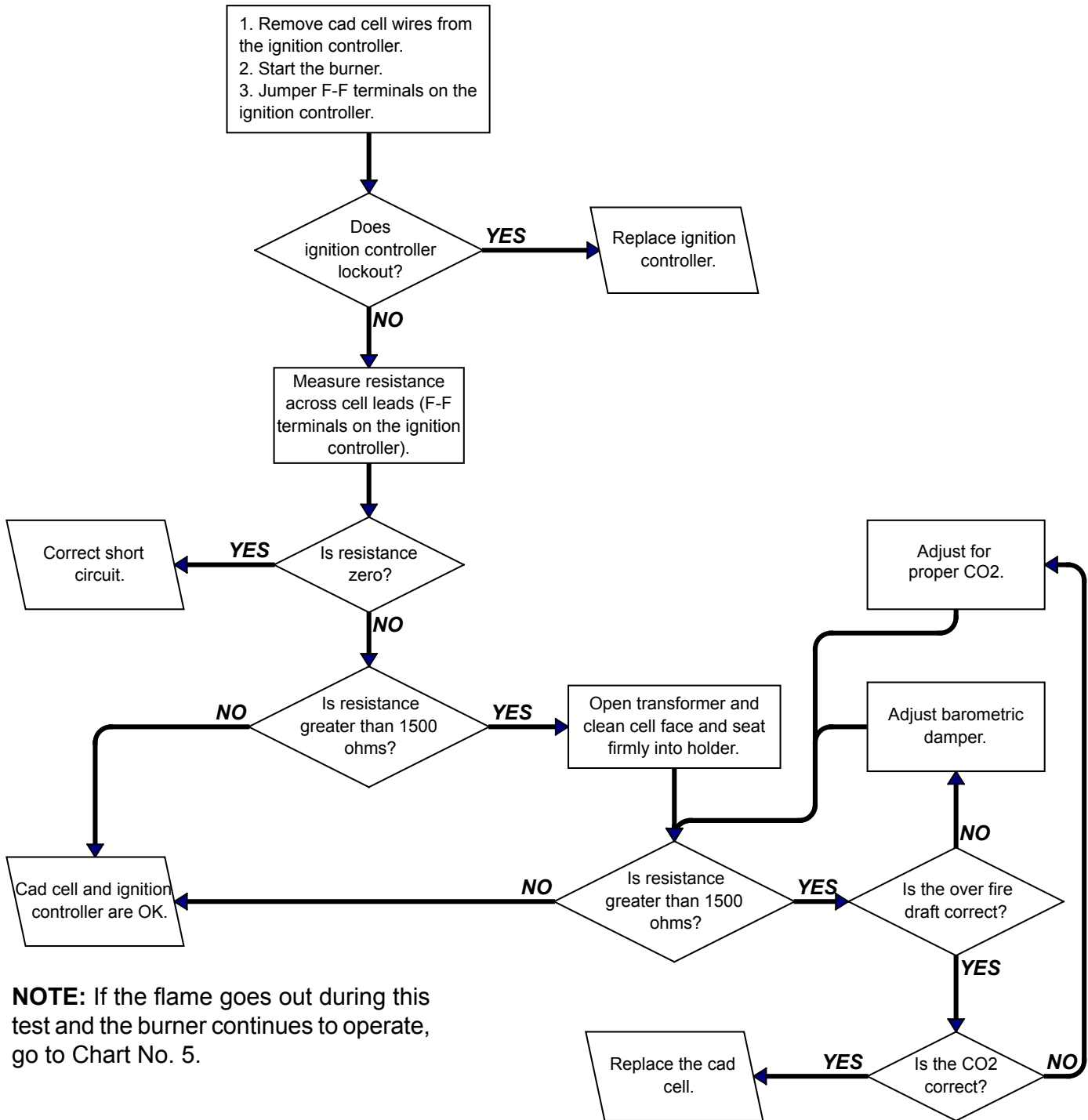

Chart No. 5 - Thermostat calling for heat. Burner operation erratic/ unstable flame pattern.

Refer to illustrations on pages 39-40.

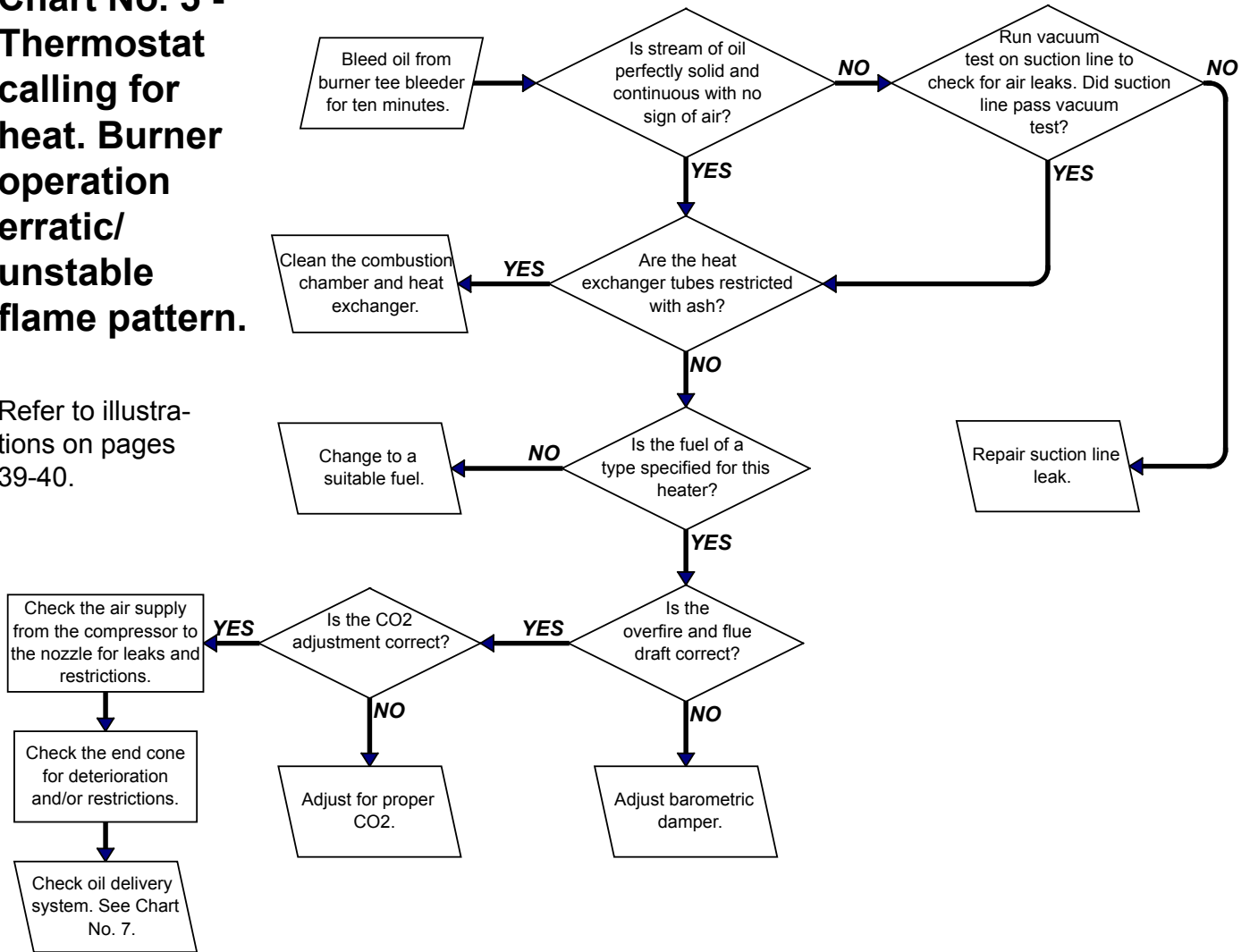
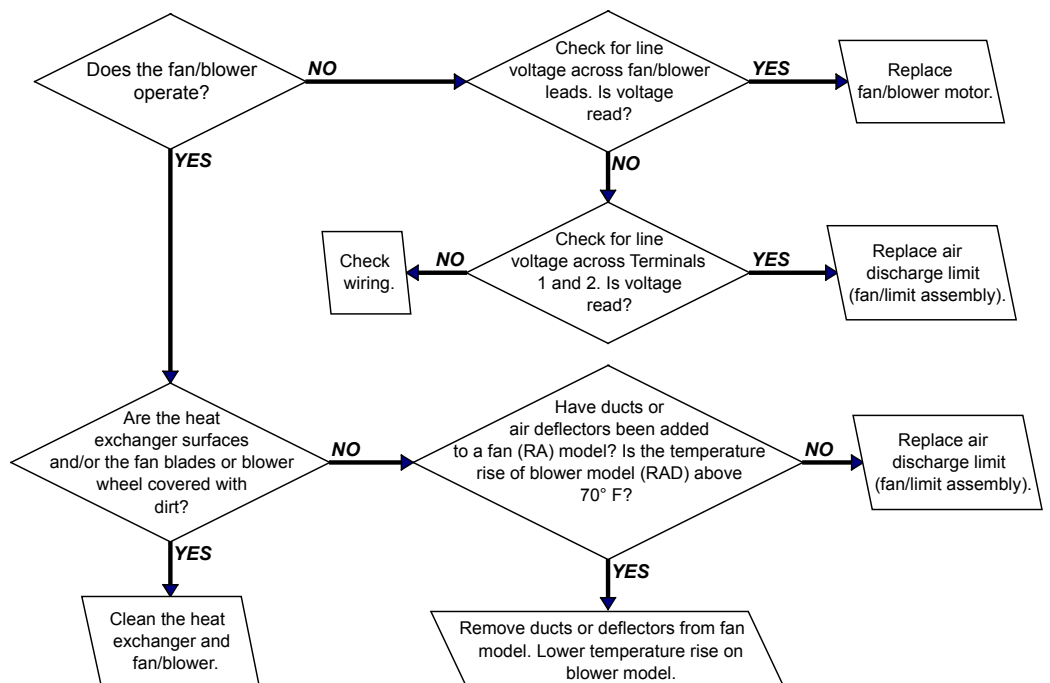

Chart No. 6 - High Temperature Limit Cycles*

Refer to illustrations on page 46.

*High temperature limit cycles when internal temperature exceeds limit set-point. Cause must be found and corrected for heater to function safely/properly.



Fan/Blower and Limit Controls

Locations and Temperature Settings - Model RA/RAD 350

- Fan/blower control (135°F)
- Automatic limit control (120°F)

RA & RAD 350

Limit and fan/blower controls are sub-assembled on a mounting plate. Access control assembly by removing the turning box door. (Cabinet parts are removed for illustration only.)

- High temperature limit control (RA350 - 210°F; RAD350 - 180°F;

RA & RAD 350 - Access the high temperature limit control through the louvers on the burner end.

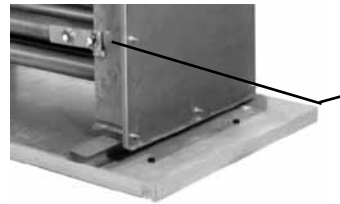

Turning Box End

Locations and Temperature Settings - Model RA/RAD 500

- Fan/blower control (175°F)
- Automatic limit control (RA500 - 210°F; RAD500 - 230°F;
- Single-use high temperature limit control (350°F)

Service Tray

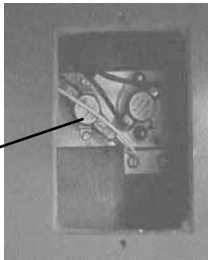

RA & RAD 500 - Limit and fan/blower controls are sub-assembled on a mounting plate. Access the control assembly by removing the cover underneath the burner service tray.

- Automatic limit control (160°F)



RA & RAD 500 - Access the limit control through the louvers on the turning box end of the unit.

Function - Fan/Blower and Limit Controls, Sizes 350 and 500

The main functions of the **fan/blower control** are to provide:

- Delay of fan or blower operation, preventing circulation of cold air at start-up.
- Continued fan or blower operation as long as the unit temperature is above minimum setting. The fan/blower control also provides additional safety control by keeping the fan or blower in operation in the event that a malfunction would cause the oil burner to continue to fire when the thermostat is satisfied.

The **circulating air high temperature limit switches** are nonadjustable and automatically cycle when the internal temperature exceeds the setpoint. For the heater to operate properly and safely, the cause for the temperature exceeding the high limit setpoint must be corrected.

The **super high temperature limit switch** on the Size 350 provides redundant control and is calibrated to open at a higher temperature than the circulating air high temperature limit switch. An interruption of the circuit by the super high limit switch indicates a major failure caused by a malfunction of the primary safety controls or miswiring. Before attempting to re-start the heater, the cause must be corrected and the fan/blower and limit controls replaced.

The **single-use high temperature limit switch** on the Size 500 provides redundant control and is calibrated to open at a higher temperature than the other limit switches. An interruption of the circuit by the single-use high limit switch indicates a major failure caused by a malfunction of the primary safety controls or miswiring. Before attempting to re-start the heater, the cause must be corrected and the fan/blower and limit controls replaced.

For Limit Control service information, see Troubleshooting Chart No. 6

Troubleshooting Continued

Chart No. 7 - Oil Delivery System

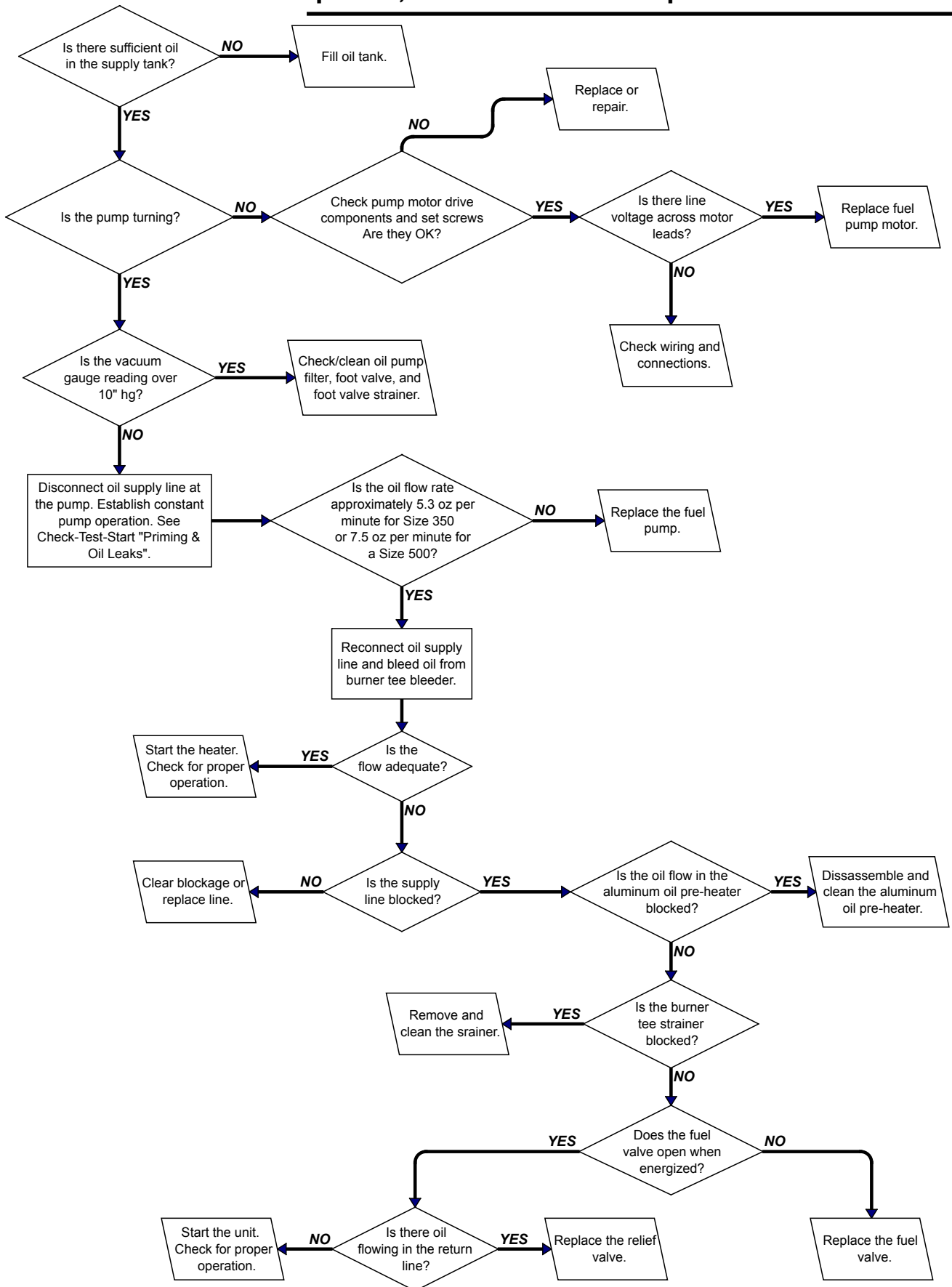

CAUTION: If the heater will be shut down for a long period, turn off the electric power.



Appendix

Wiring Diagram 147351 for Models RA/RAD 350

WIRING CODE
 BLACK - BK
 BROWN - BR
 RED - R
 ORANGE - O
 YELLOW - Y
 GREEN - G
 BLUE - BL
 PURPLE - PR
 WHITE - W

 CONNECTION IN FAN/BLOWER JUNCTION BOX
 CONNECTION IN OIL HEATER COMPARTMENT
 CONNECTION IN PUMP ENCLOSURE

 FACTORY WIRING
 FIELD WIRING
 TERMINAL STRIP - BURNER JUNCTION BOX
 TERMINAL BLOCK - MAIN CONTROL BOX

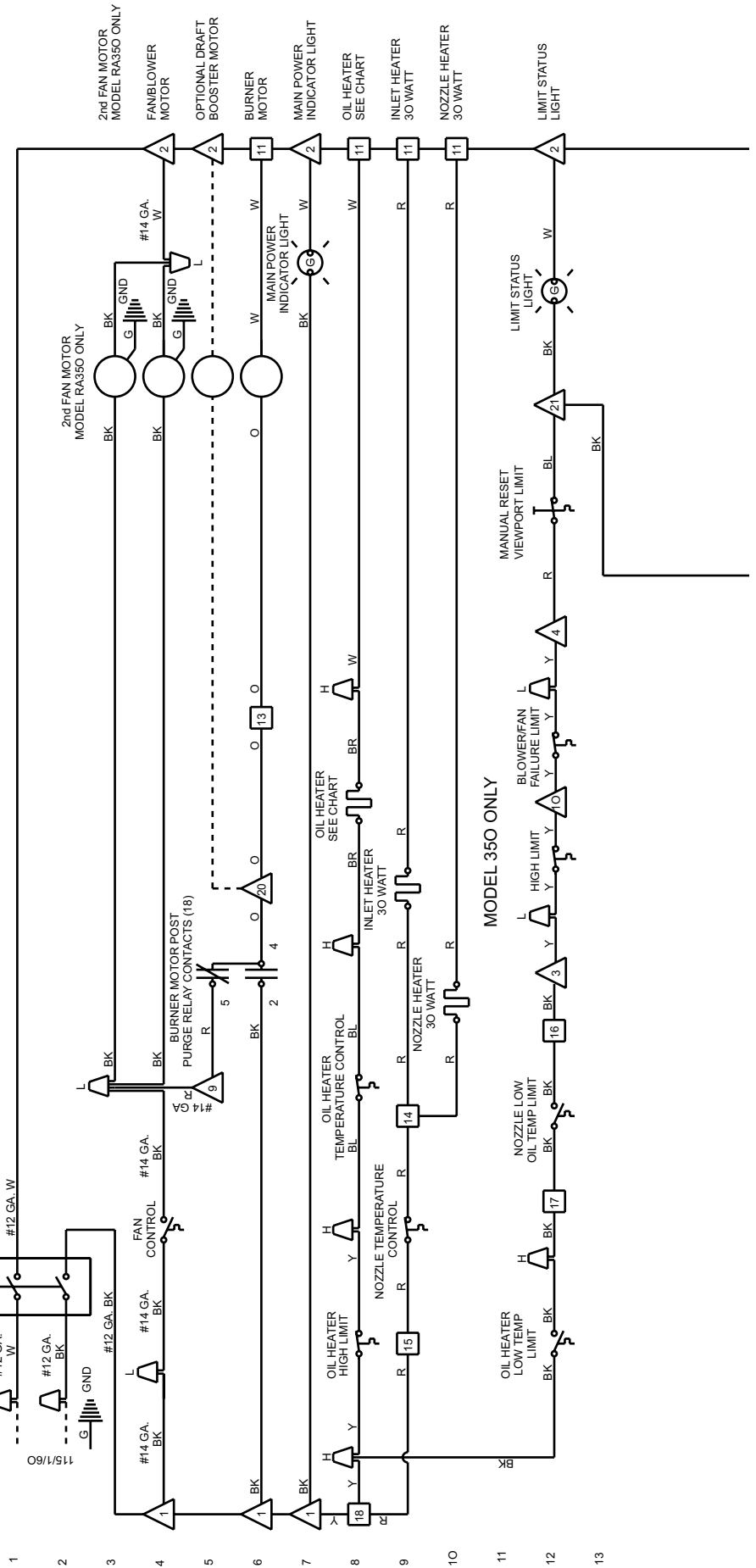

14

CONTROL TEMPERATURE LIMITS			
CONTROL	STYLE	ACTIVATE	RESET
FAN CONTROL	NO	135°F	105°F
HIGH LIMIT	NC	220°F	45°F
OIL HEATER TEMP CONTROL	NC	170°F	155°F
NOZZLE TEMP CONTROL	NC	160°F	150°F
OIL HEATER LOW TEMP LIMIT	NO	140°F	140°F
NOZZLE LOW OIL TEMP LIMIT	NO	145°F	105°F
SUPER HIGH LIMIT	NC	350°F	N/A
HIGH LIMIT (MODEL RA350)	NC	210°F	170°F
HIGH LIMIT (MODEL RAD350)	NC	180°F	150°F
FAN/BLOWER FAILURE LIMIT	NC	120°F	90°F
MANUAL RESET VIEWPORT LIMIT	NC	275°F	45°F

15

OIL HEATER CHART	
UNIT SIZE	OIL HEATER WATTS
350	650

16

17

18

19

FIELD CONNECTION CHART

SOURCE	TO LOCATION	COLOR	CONNECTION TYPE	GAUGE
115 V POWER SUPPLY	MAIN JUNCTION BOX	BLACK	WIRE NUT--BLACK WIRE	RA 12 MIN; RAD 8 MIN
115 V POWER SUPPLY	MAIN JUNCTION BOX	WHITE	WIRE NUT--WHITE WIRE	RA 12 MIN; RAD 8 MIN
REMOTE PUMP	MAIN JUNCTION BOX	BARE/GRN	WIRE NUT--GREEN WIRE	RA 12 MIN; RAD 8 MIN
REMOTE PUMP	MAIN JUNCTION BOX	BLACK	TERMINAL BLOCK 6	14 MIN
REMOTE PUMP	MAIN JUNCTION BOX	WHITE	TERMINAL BLOCK 2	14 MIN
REMOTE PUMP	MAIN JUNCTION BOX	BARE/GRN	GROUND TERMINAL	14 MIN
THERMOSTAT	IGNITION CONTROL	WHITE	TERMINAL T1 SCREW	18 MIN
THERMOSTAT	IGNITION CONTROL	RED	TERMINAL T2 SCREW	18 MIN
OPT. EXHAUST BOOSTER	MAIN JUNCTION BOX	BLACK	TERMINAL BLOCK 19	14 MIN
OPT. EXHAUST BOOSTER	MAIN JUNCTION BOX	WHITE	TERMINAL BLOCK 2	14 MIN
OPT. EXHAUST BOOSTER	MAIN JUNCTION BOX	BARE/GRN	GROUND TERMINAL	14 MIN

20

21

22

23

24

SHORTENED SEQUENCE OF OPERATION

SEE INSTALLATION & OPERATION INSTRUCTIONS FOR FULL DETAILS
1. WITH POWER SUPPLIED AND DISCONNECT SWITCH "ON", OIL HEATERS PREHEAT OIL.
2. ON CALL FOR HEAT, THERMOSTAT CLOSES CAUSING IGNITION CONTROLLER TO ENERGIZE BURNER MOTOR, ATOMIZING AIR COMPRESSOR, REMOTE OIL PUMP AND IGNITION TRANSFORMER.
3. OIL IS IGNITED AND FLAME ESTABLISHED.
4. 30 - 45 SECONDS AFTER BEGINNING OF SEQUENCE, OR FAN CONTROL ACTIVATES AIR MOVING DEVICE(S).
5. WHEN THERMOSTAT IS SATISFIED, POWER IS REMOVED FROM IGNITION CONTROLLER, DE-ENERGIZING BURNER MOTOR, ATOMIZING AIR COMPRESSOR AND REMOTE OIL PUMP.
6. AIR MOVING DEVICE(S) CONTINUE TO OPERATE UNTIL EITHER
A) HEAT EXCHANGER IS COOL (NOMINAL 3 MINUTES)
B) IF IGNITION DOES NOT OCCUR WITHIN 30 SECONDS THE IGNITION CONTROLLER WILL LOCK OUT. IF THE UNIT LOCKS OUT, RESET THE CONTROLLER BY PRESSING AND HOLDING DOWN ON THE RED RESET BUTTON FOR (4) SECONDS AND THEN RELEASING IT. DO NOT RESET MORE THAN ONE TIME !

25

26

27

CAUTION: IF ANY OF THE ORIGINAL WIRE AS SUPPLIED WITH THE APPLIANCE MUST BE REPLACED, IT MUST BE REPLACED WITH WIRING MATERIAL HAVING A TEMPERATURE RATING OF AT LEAST 105°C. EXCEPT FOR HEATING ELEMENT, FAN CONTROL AND LIMIT WIRING WHICH MUST BE 150°C.

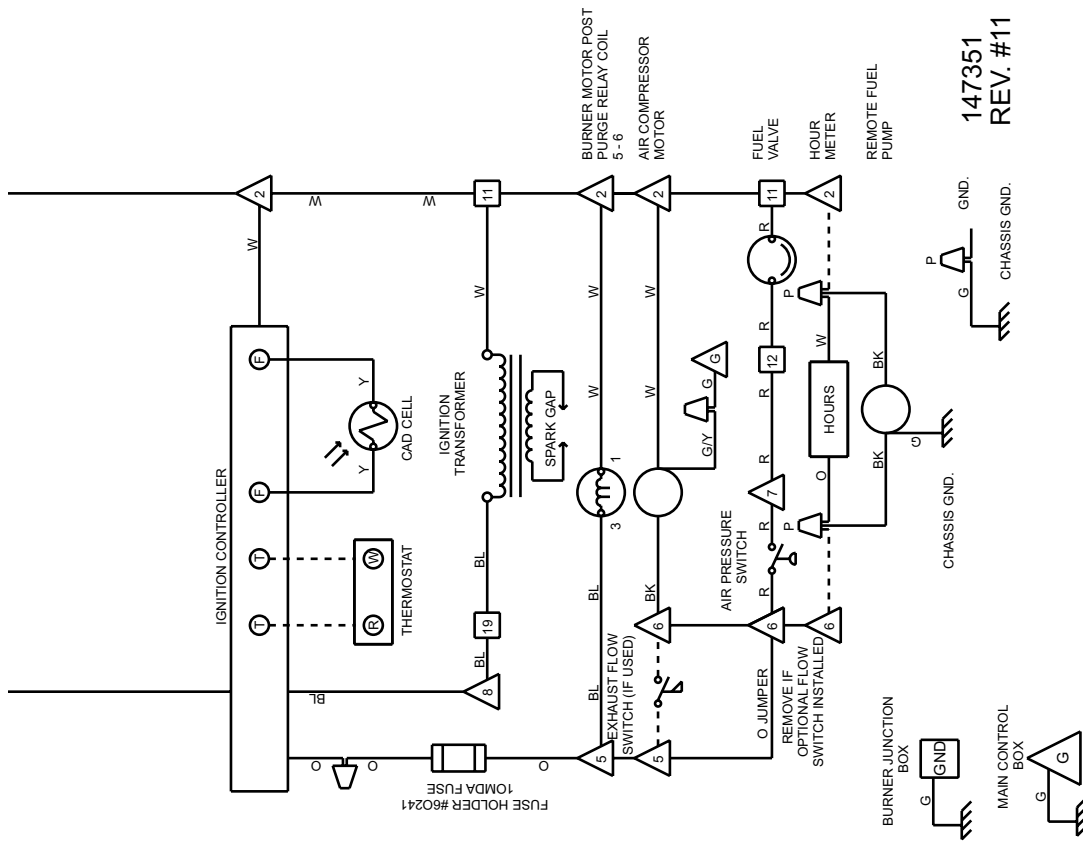

147351
REV. #11

RA(D) 350 DWG. #B-147351 REV. #11

Note: W. D. 147351 covers Sizes 140, 235, and 350. Information specific to Sizes 140 and 235 has been removed in this publication.

147351
REV. #11

Wiring Diagram 189994, Model RA500 (fan model)

IMPORTANT NOTE: This is the current wiring diagram. If your Model RA500 heater was manufactured before 1/05 (Serial No. Code BEA), see wiring diagram on pages 54-55.

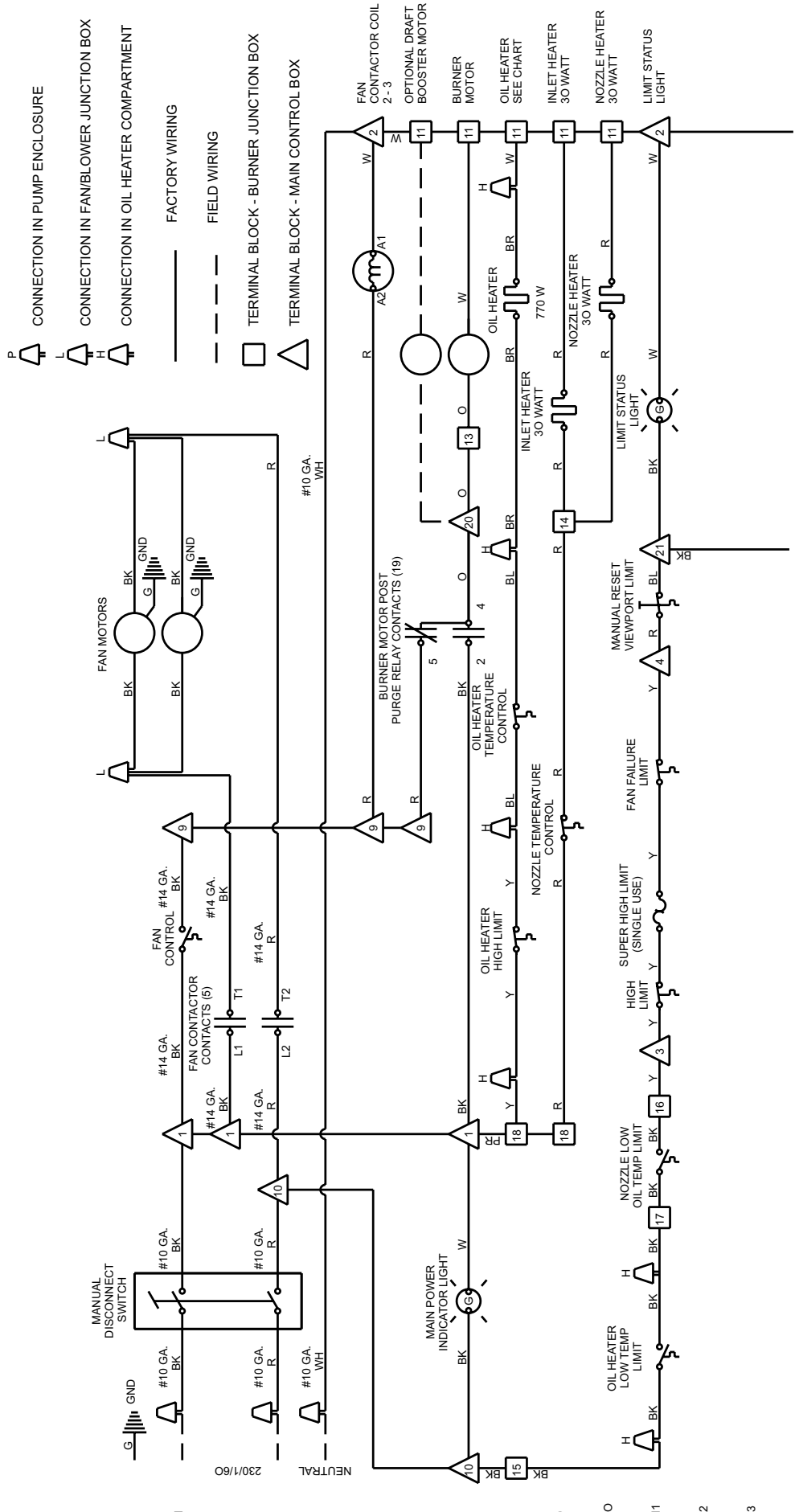

CONTROL TEMPERATURE LIMITS			
CONTROL	STYLE	ACTIVATE	RESET
FAN CONTROL	NO	175°F	155°F
OIL HEATER HIGH LIMIT	NC	220°F	45°F
OIL HEATER TEMP CONTROL	NC	170°F	155°F
NOZZLE TEMP CONTROL	NO	160°F	150°F
OIL HEATER LOW TEMP LIMIT	NO	155°F	140°F
NOZZLE LOW OIL TEMP LIMIT	NO	145°F	105°F
HIGH LIMIT	NC	210°F	170°F
SUPER HIGH LIMIT	NC	350°F	N/A
FAN/BLOWER FAILURE LIMIT	NC	145°F	120°F
MANUAL RESET VIEWPORT LIMIT	NC	275°F	45°F

WIRING CODE
 BLACK - BK
 BROWN - BR
 RED - R
 ORANGE - O
 YELLOW - Y
 GREEN - G
 BLUE - BL
 PURPLE - PR
 WHITE - W

FIELD CONNECTION CHART			
SOURCE	TO LOCATION	COLOR	CONNECTION TYPE
230 V POWER SUPPLY	MAIN JUNCTION BOX	BLACK	WIRE NUT-BLACK WIRE
230 V POWER SUPPLY	MAIN JUNCTION BOX	WHITE	WIRE NUT-WHITE WIRE
230 V POWER SUPPLY	MAIN JUNCTION BOX	BARE/GRN	WIRE NUT-GREEN WIRE
230 V POWER SUPPLY	MAIN JUNCTION BOX	RED	WIRE NUT-RED WIRE
REMOTE PUMP	MAIN JUNCTION BOX	BLACK	TERMINAL BLOCK 6
REMOTE PUMP	MAIN JUNCTION BOX	WHITE	TERMINAL BLOCK 2
REMOTE PUMP	MAIN JUNCTION BOX	BARE/GRN	GROUND TERMINAL
THERMOSTAT	IGNITION CONTROL	WHITE	TERMINAL T1 SCREW
THERMOSTAT	IGNITION CONTROL	RED	TERMINAL T2 SCREW
OPT. EXHAUST BOOSTER	MAIN JUNCTION BOX	BLACK	TERMINAL BLOCK 19
OPT. EXHAUST BOOSTER	MAIN JUNCTION BOX	WHITE	TERMINAL BLOCK 2
OPT. EXHAUST BOOSTER	MAIN JUNCTION BOX	BARE/GRN	GROUND TERMINAL

SHORTENED SEQUENCE OF OPERATION

SEE INSTALLATION & OPERATION INSTRUCTIONS FOR FULL DETAILS

1. WITH POWER SUPPLIED AND DISCONNECT SWITCH "ON", OIL HEATERS PREHEAT OIL.
2. ON CALL FOR HEAT, THERMOSTAT CLOSURES CAUSING IGNITION CONTROLLER TO ENERGIZE BURNER MOTOR, ATOMIZING AIR COMPRESSOR, REMOTE OIL PUMP AND IGNITION TRANSFORMER.
3. OIL IS IGNITED AND FLAME ESTABLISHED.
4. 30 - 45 SECONDS AFTER BEGINNING OF SEQUENCE, OR FAN CONTROL ACTIVATES AIR MOVING DEVICE(S).
5. WHEN THERMOSTAT IS SATISFIED, POWER IS REMOVED FROM IGNITION CONTROLLER, DE-ENERGIZING BURNER MOTOR, ATOMIZING AIR COMPRESSOR AND REMOTE OIL PUMP.
6. AIR MOVING DEVICE(S) CONTINUE TO OPERATE UNTIL HEAT EXCHANGER IS COOL. (NOMINAL 3 MINUTES)
7. IF IGNITION DOES NOT OCCUR WITHIN 30 SECONDS THE IGNITION CONTROLLER WILL LOCK OUT. IF THE UNIT LOCKS OUT, RESET THE CONTROLLER BY PRESSING AND HOLDING DOWN ON THE RED RESET BUTTON FOR (4) SECONDS AND THEN RELEASING IT. DO NOT RESET MORE THAN ONE TIME!

CAUTION: IF ANY OF THE ORIGINAL WIRE AS SUPPLIED WITH THE APPLIANCE MUST BE REPLACED. IT MUST BE REPLACED WITH WIRING MATERIAL HAVING A TEMPERATURE RATING OF AT LEAST 105°C. EXCEPT FOR HEATING ELEMENT, FAN CONTROL AND LIMIT WIRING WHICH MUST BE 150°C.

189994 REV. #2

RA 500 DWG. #B-189994 REV. #2 IJB

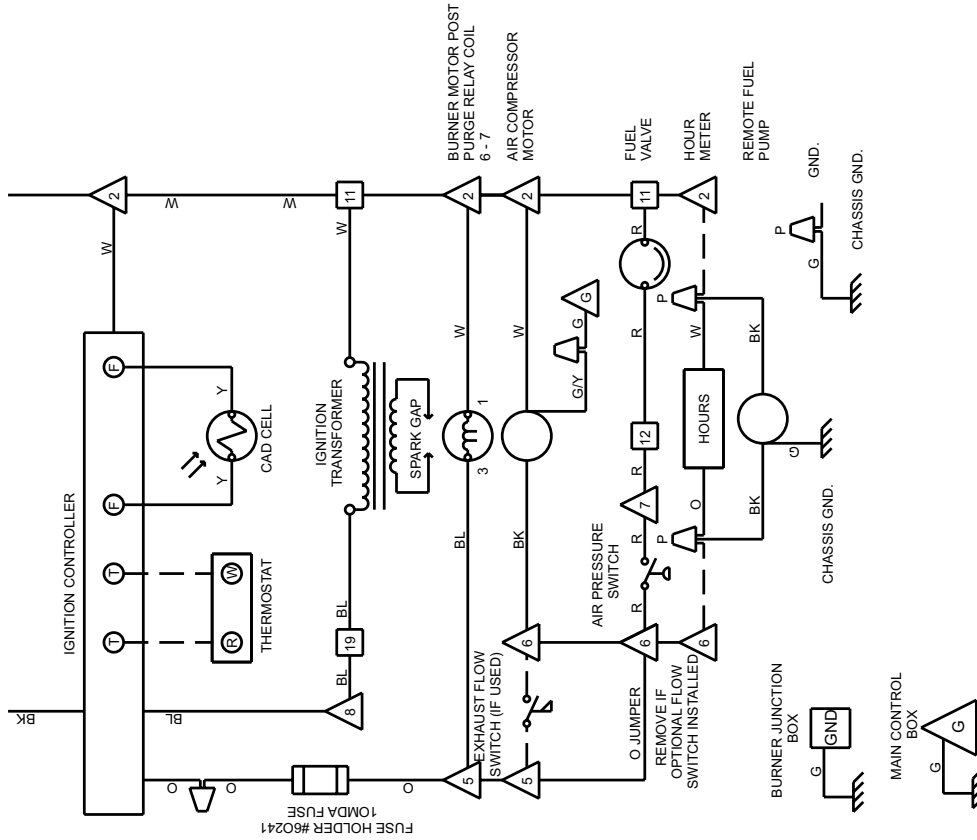

Wiring Diagram 224503, Model RAD500 (blower model)
IMPORTANT NOTE: This is the current wiring diagram. If your Model RAD500 heater was manufactured before 1/05 (Serial No. Code BEA), see wiring diagram on pages 56-57.

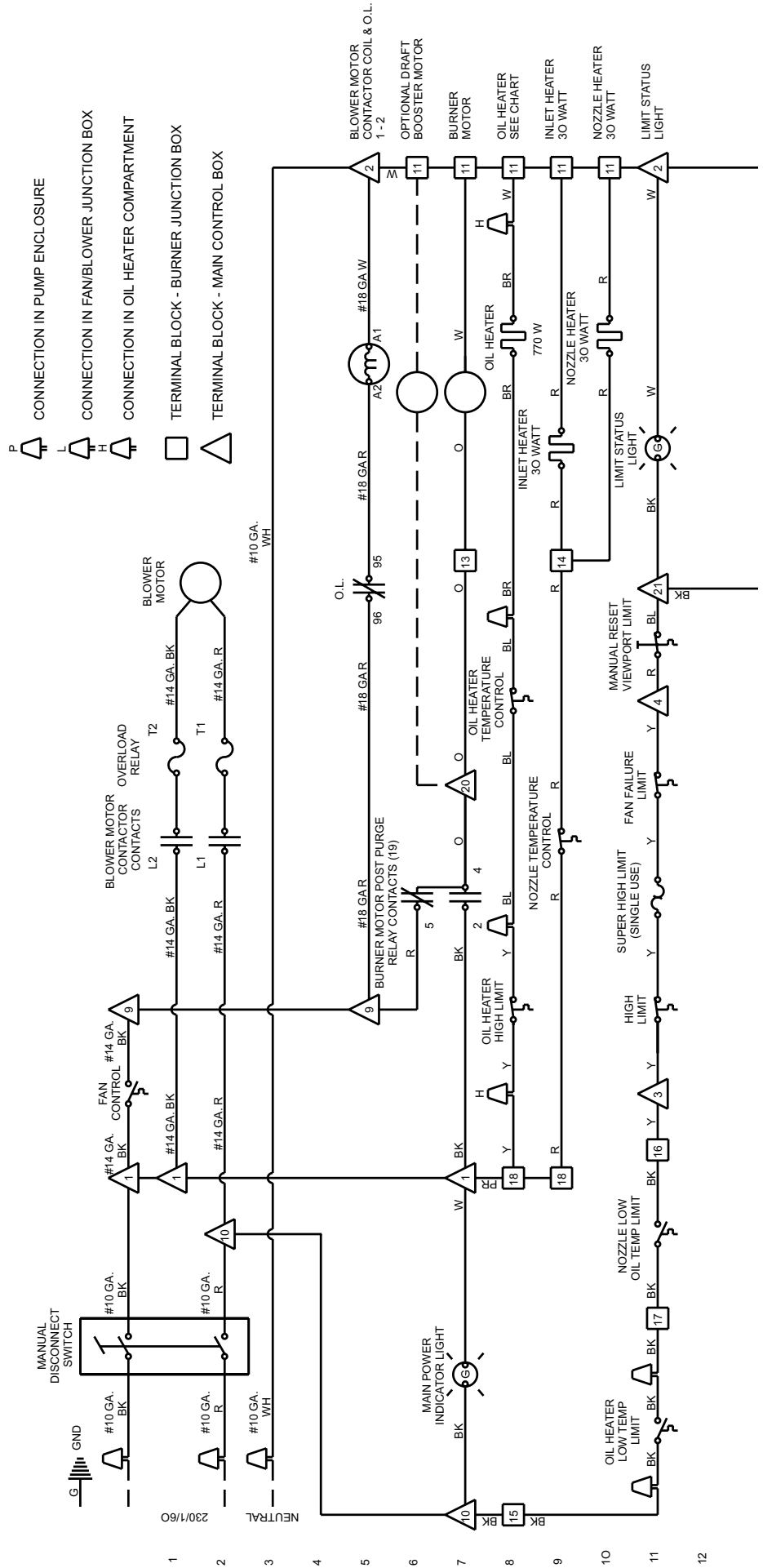

CONTROL TEMPERATURE LIMITS			
CONTROL	STYLE	ACTIVATE	RESET
FAN CONTROL	NO	175°F	155°F
OIL HEATER HIGH LIMIT	NC	220°F	45°F
OIL HEATER TEMP CONTROL	NC	170°F	155°F
NOZZLE TEMP CONTROL	NC	160°F	150°F
OIL HEATER LOW TEMP LIMIT	NO	135°F	140°F
NOZZLE LOW OIL TEMP LIMIT	NO	145°F	105°F
HIGH LIMIT	NC	210°F	170°F
SUPER HIGH LIMIT	NC	350°F	N/A
FAN/BLOWER FAILURE LIMIT	NC	145°F	120°F
MANUAL RESET VIEWPORT LIMIT	NC	275°F	45°F

FIELD CONNECTION CHART

SOURCE	TO LOCATION	COLOR	CONNECTION TYPE	GAUGE
230 V POWER SUPPLY	MAIN JUNCTION BOX	BLACK	WIRE NUT-BLACK WIRE	10 MIN
230 V POWER SUPPLY	MAIN JUNCTION BOX	WHITE	WIRE NUT-WHITE WIRE	10 MIN
230 V POWER SUPPLY	MAIN JUNCTION BOX	BARE/GRN	WIRE NUT-GREEN WIRE	10 MIN
REMOTE PUMP	MAIN JUNCTION BOX	RED	WIRE NUT-RED WIRE	10 MIN
REMOTE PUMP	MAIN JUNCTION BOX	BLACK	TERMINAL BLOCK 6	14 MIN
REMOTE PUMP	MAIN JUNCTION BOX	WHITE	TERMINAL BLOCK 2	14 MIN
THERMOSTAT	IGNITION CONTROL	BARE/GRN	GROUND TERMINAL	14 MIN
THERMOSTAT	IGNITION CONTROL	WHITE	TERMINAL T1 SCREW	18 MIN
OPT. EXHAUST BOOSTER	MAIN JUNCTION BOX	RED	TERMINAL T2 SCREW	14 MIN
OPT. EXHAUST BOOSTER	MAIN JUNCTION BOX	BLACK	TERMINAL BLOCK 19	14 MIN
OPT. EXHAUST BOOSTER	MAIN JUNCTION BOX	WHITE	TERMINAL BLOCK 2	14 MIN
OPT. EXHAUST BOOSTER	MAIN JUNCTION BOX	BARE/GRN	GROUND TERMINAL	14 MIN

SHORTENED SEQUENCE OF OPERATION

- SEE INSTALLATION & OPERATION INSTRUCTIONS FOR FULL DETAILS
- WITH POWER SUPPLIED AND DISCONNECT SWITCH "ON", OIL HEATERS PREHEAT OIL.
 - ON CALL FOR HEAT, THERMOSTAT CLOSURES CAUSING IGNITION CONTROLLER TO ENERGIZE BURNER MOTOR, ATOMIZING AIR COMPRESSOR, REMOTE OIL PUMP AND IGNITION TRANSFORMER.
 - OIL IS IGNITED AND FLAME ESTABLISHED.
 - 30 - 45 SECONDS AFTER BEGINNING OF SEQUENCE, OR FAN CONTROL ACTIVATES AIR MOVING DEVICE(S).
 - WHEN THERMOSTAT IS SATISFIED, POWER IS REMOVED FROM IGNITION CONTROLLER, DE-ENERGIZING BURNER MOTOR, ATOMIZING AIR COMPRESSOR AND REMOTE OIL PUMP.
 - AIR MOVING DEVICE(S) CONTINUE TO OPERATE UNTIL HEAT EXCHANGER IS COOL. (NOMINAL 3 MINUTES)
 - IF IGNITION DOES NOT OCCUR WITHIN 30 SECONDS THE IGNITION CONTROLLER WILL LOCK OUT. IF THE UNIT LOCKS OUT, RESET THE CONTROLLER BY PRESSING AND HOLDING DOWN ON THE RED RESET BUTTON FOR (4) SECONDS AND THEN RELEASING IT. DO NOT RESET MORE THAN ONE TIME!

CAUTION: IF ANY OF THE ORIGINAL WIRE AS SUPPLIED WITH THE APPLIANCE MUST BE REPLACED, IT MUST BE REPLACED WITH WIRING MATERIAL HAVING A TEMPERATURE RATING OF AT LEAST 105°C. EXCEPT FOR HEATING ELEMENT, FAN CONTROL AND LIMIT WIRING WHICH MUST BE 150°C.

224503 REV. #3

RAD 500 DWG. #B-224503 REV. #3 IJB

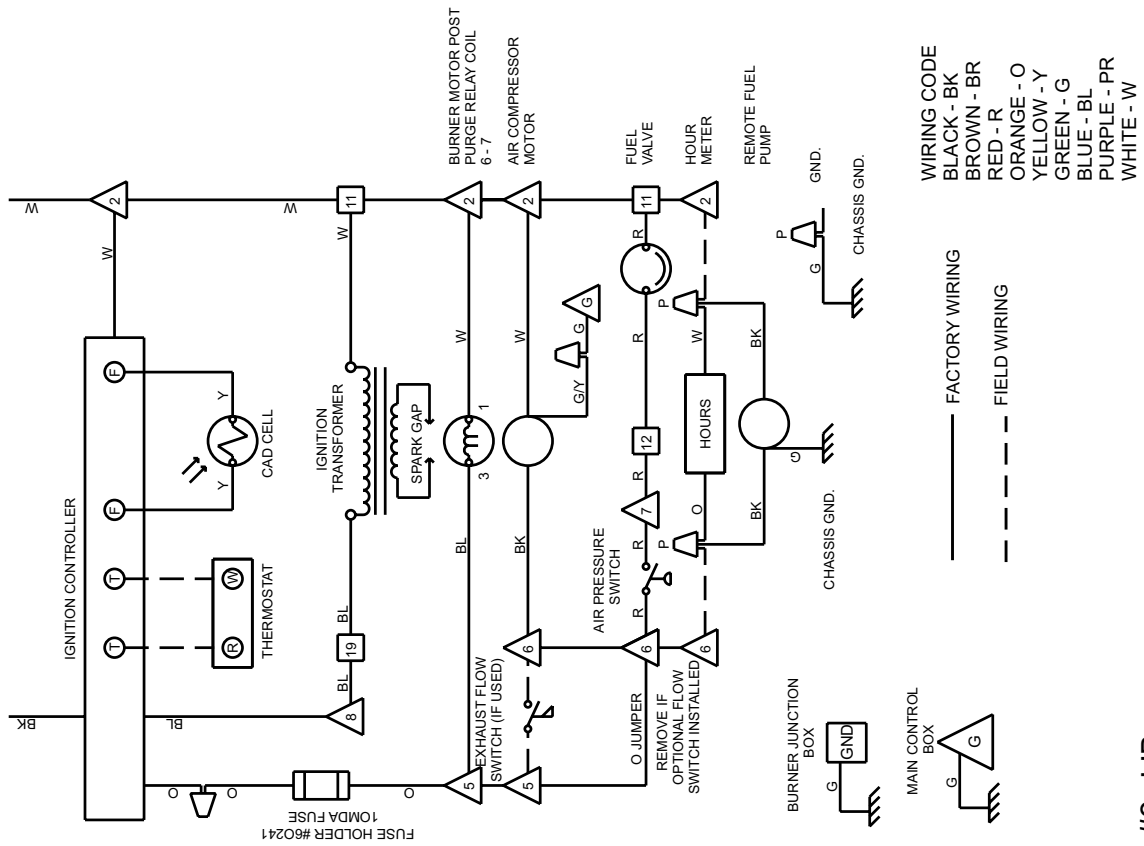

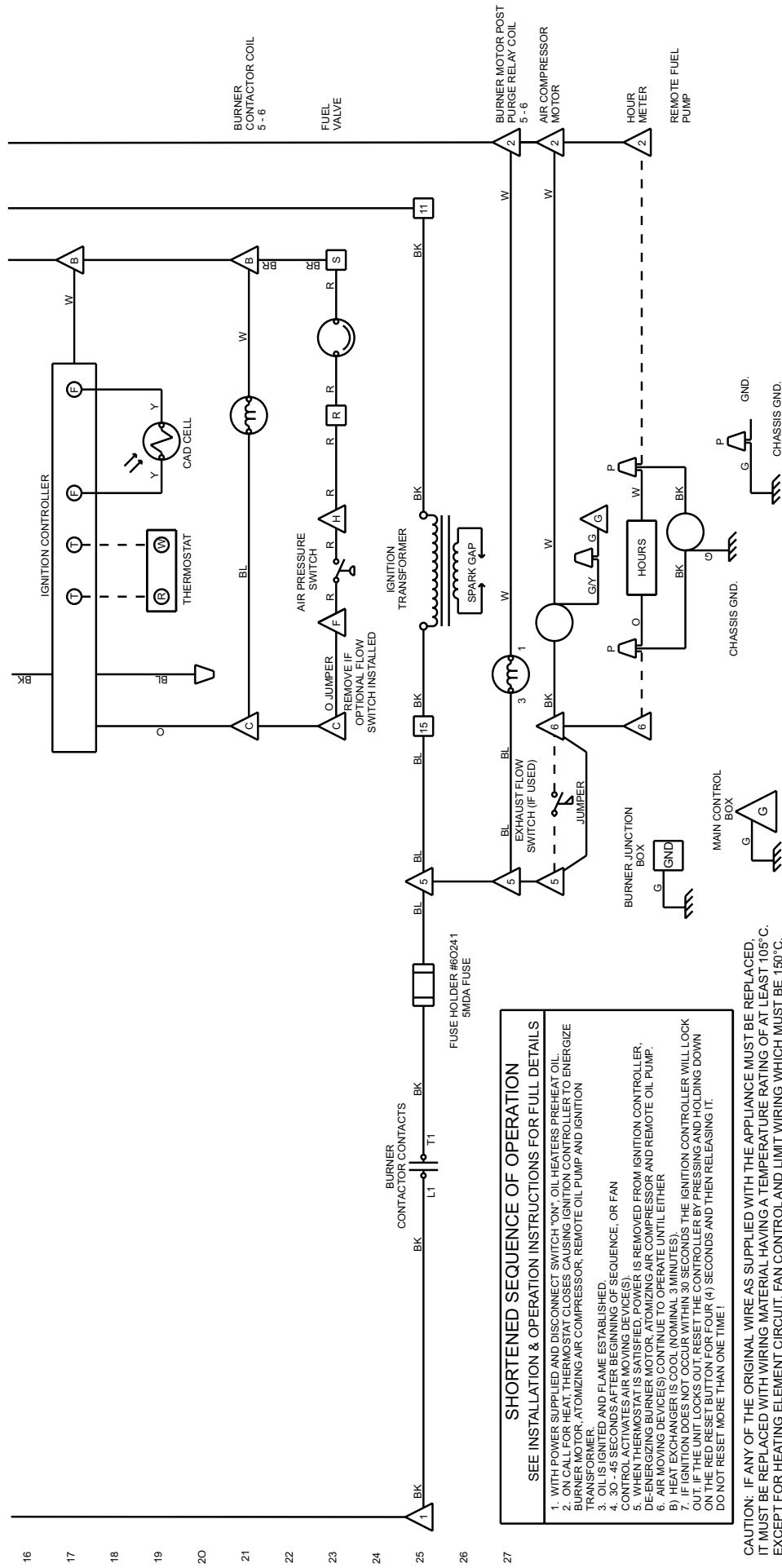

156434 REV#7

- WIRING CODE**
 BLACK - BK
 BROWN - BR
 RED - R
 ORANGE - O
 YELLOW - Y
 GREEN - G
 BLUE - BL
 PURPLE - PR
 WHITE - W
- CONNECTION IN FAN JUNCTION BOX**
 L
 H
- CONNECTION IN OIL HEATER COMPARTMENT**
 P
- CONNECTION IN PUMP ENCLOSURE**
 P
- FACTORY WIRING**

- FIELD WIRING**
 - - - - -
- TERMINAL STRIP - BURNER JUNCTION BOX**
 □
- TERMINAL BLOCK - MAIN CONTROL BOX**
 ▽

Wiring Diagram 156434, Model RAD500 (blower model) mfgd prior to 1/2005
IMPORTANT NOTE: This wiring diagram is for a Model RAD500 heater
MANUFACTURED BEFORE 1/05 (Serial No. Code BEA), See pages 52-53 for current
wiring diagram.

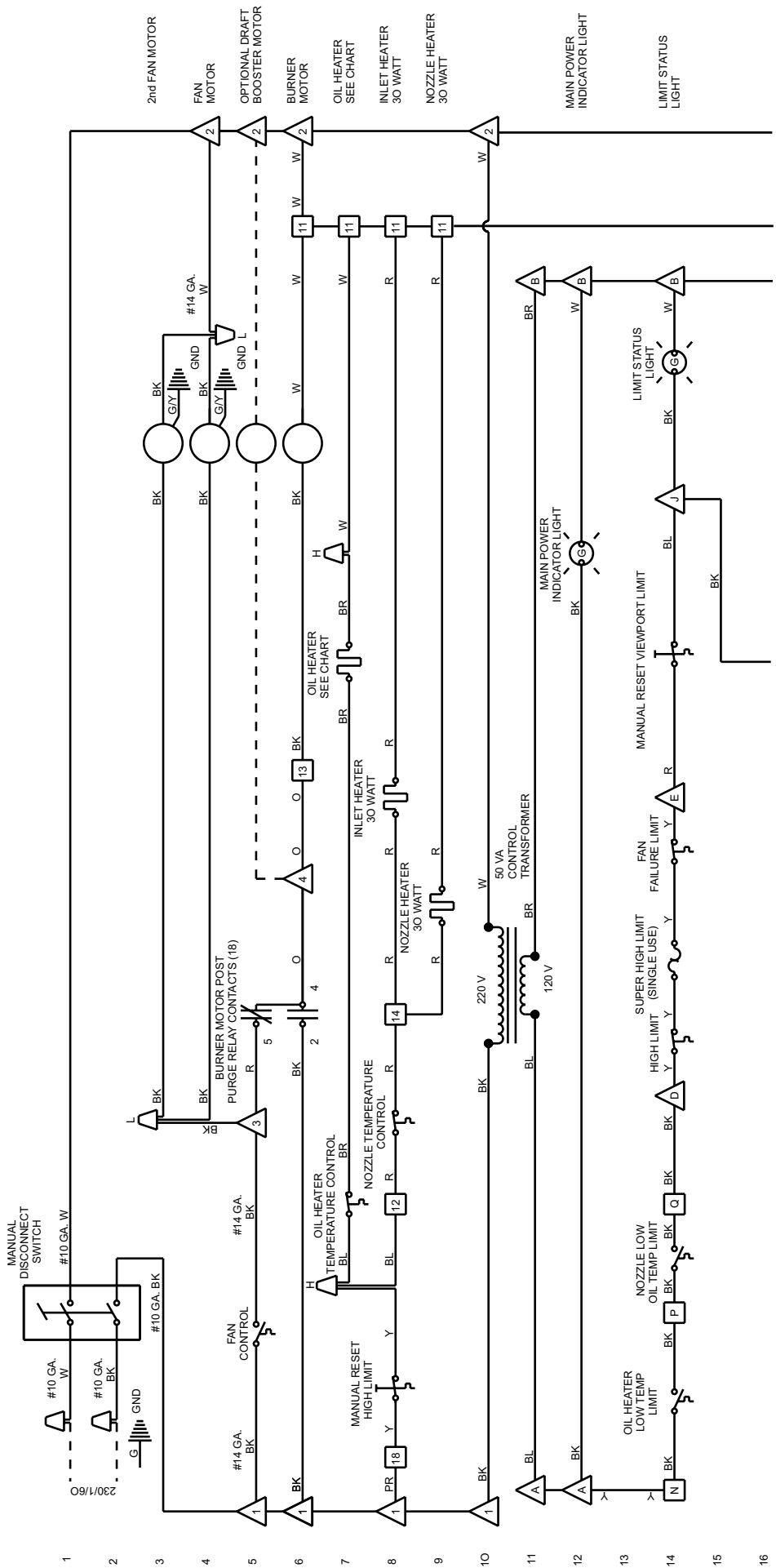

Index

A

Air Band and Air Shutter Settings 22
Air for Combustion 6
Air Shutter and Air Band Settings 22

B

Backflow Sensor Switch 37
Belt Tension 6
Burner 31

C

Chimney 14
Cleaning Record 58
Clearances from Combustibles 8
Codes and Regulations 4
Combustion Chamber 27
Compressed Air Filter 30

D

Discharge Air Temperature 23
Barometric Draft Regulator 15
Draft Inducer 16
Draft Inducer Relay 16
Draft Regulator 16
Discharge Duct 17
Inlet Air Duct 17

E

Electrode Adjustment 33
Electrodes 31
End Cone 31

F

Fan/blower control 46
Fuel Line Assembly 32, 33, 42
Fuels 5
Fuel Tank 10

H

Hazardous Atmosphere 5
Heat Exchanger 28
High Altitude Installation 9
High Temperature Limit 45

I

Indicator Lights 37
Inspecting and Cleaning 27
Introduction 4

L

Tank Warning Label 23
Limit Controls 46
Location of Components 39, 40

M

Maintenance Procedures 25
Maintenance Requirements 24
Maintenance Schedule 24
Measuring Draft Over Fire 21

N

Nozzle 31

O

Oil Burner Troubleshooting 37
Oil Delivery System 47
Oil Heat Exchanger 42
Operation 35

P

Parts Carton 7
Heater Placement 8
Main Power 18
Pre-Heater System 33
Priming and Leak Check 19
Pump 10, 11
Pump Power 18

R

Recharging the Suction Line 26
Removing Soot and Ash - Size 350 28
Removing Soot and Ash - Size 500 30

S

Internal Pump Screen 25, 26
Secondary Heat Source 5
Service 35
service access 8
Spark Electrodes 32
Burner Oil Strainer 26
Start-Up 19
Start-Up Procedure 21
Supply Line Filter 25
Supply Lines 10, 11
Suspension 13
Swivel connections 13
System Check 19

T

Thermostat 18
Transformer and Electrode Checks 43
Troubleshooting Chart Guide 38
Typical Installation 12

U

Unpacking 6

V

Vacuum Gauge 23, 24
Detailed Requirements for the Vent System 15
Venting 5, 14
Vent Size 15
Viewport Cover 37

W

Warnings 5
Warranty 4
Weight 13
Wiring Diagram 48, 50, 52, 54, 56

**CAUTION: DO NOT TAMPER WITH THE UNIT OR CONTROLS.
CALL YOUR SERVICE PERSON.**

INSTALLER MUST COMPLETE THE FOLLOWING:

Installer:

Name _____

Company _____

Address _____

Phone _____

Distributor (company from which the unit was purchased):

Company _____

Contact _____

Address _____

Phone _____

Model _____ **Serial No.** _____ **Date of Installation** _____

SPECIFIC INSTALLATION NOTES: (i.e. Location, Amps, Temperature, Voltage, Adjustments, Warranty, etc.)

BUILDING OWNER OR MAINTENANCE PERSONNEL:

For service or repair

- Contact the installer listed above.
- If you need additional assistance, contact the Reznor Distributor listed above.
- For more information, contact your Reznor Representative by calling (800) 695-1901.

**Reznor, LLC
150 McKinley Avenue
Mercer, PA 16137**



www.ReznorHVAC.com; (800) 695-1901

©2015 Reznor, LLC. All rights reserved.

Trademark Note: Reznor® is registered in at least the United States.

0415 Form I-RA/D 350/500 (Version C.6)

REZNOR®