

**Installation Form for Option CD1,
Vertical Louvers**

Applies to: **Model OH 95, 140, and 190
and Models RA/RAD 350**

**Description/
Application**

Optional vertical louvers require field assembly and installation. The assembled louvers fit in the air discharge over the factory-installed horizontal louvers. Vertical louvers provide a more dispersed air distribution pattern.

Components of each package are listed in the table below. Before beginning installation, verify that the package is compatible with the heater model and size.

Model	OH95		OH140/190		RA/RAD350	
Option Package	P/N 121858		P/N 121859		P/N 144963	
Components:	Qty	P/N	Qty	P/N	Qty	P/N
Top and Bottom Members	2	119859	2	119860		--
Top Left/Bottom Right Members		--		--	2	144432
Top Right/Bottom Left Members		--		--	2	144433
Vertical Louvers	10	95937	14	95937	16	95938
Sheetmetal Screws, #10 x 1/2" lg	20	11813	28	11813	34	11813
Teks (self-drilling screws), #10-16 x 1/2" lg	4	37661	6	37661	14	37661

WARNING

Improper installation, adjustment, alteration, service, or maintenance can cause property damage, injury or death. Read the installation, operation, and maintenance instructions thoroughly before installing or servicing this equipment. Service should be done by a qualified service person.

**Installation
Instructions**

Installation should be done by a qualified agency in accordance with these instructions and in compliance with all codes and requirements of authorities having jurisdiction. Select the Section that applies to the model and size of heater being serviced.

**Section A - Applies to
Option Packages for
Model OH 95, 140, and
190 (See FIGURE 1)**

- Assemble vertical louvers to the top and bottom members using the sheetmetal screws provided.
 - Vertical louver edges should extend beyond the front outer edge of the louver top and bottom members.
 - Stops are designed so that the louvers on the right turn right and the louvers on the left turn left.
- If the heater is installed, turn off the power supply before installing the vertical louvers. Attach the vertical louver assembly using the holes in the front heater panels and the TEKS (self-drilling screws) in the option package. Adjust both the horizontal and vertical louvers to provide the desired air direction.
- If the heater is installed, restore power and check operation.

**FIGURE 1 - Vertical Louver
Assembly and Installation on
Model OH/95/140/190**

CAUTION: To avoid getting burned, adjust louvers while the heater is not in operation. If louvers are adjusted while the heater is in operation, wear protective gloves.

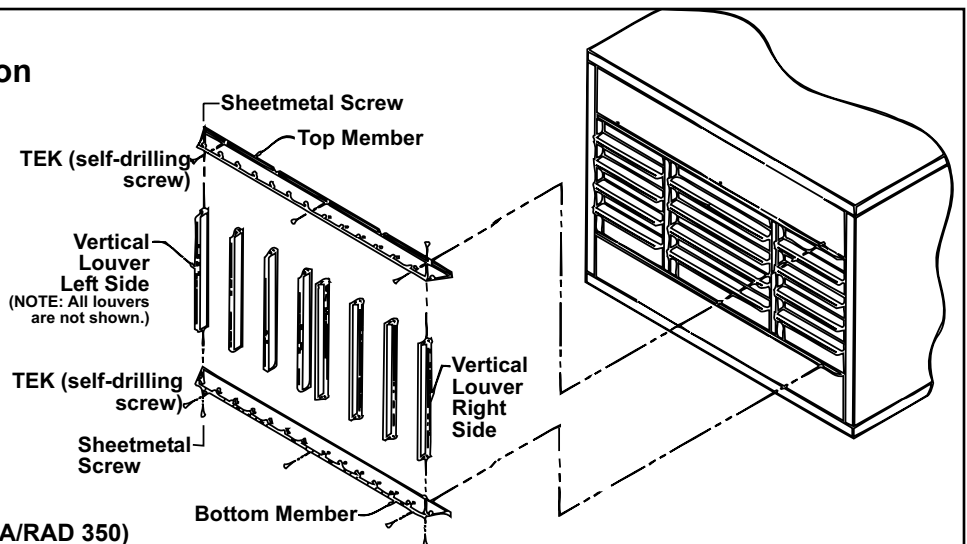

(See Section B, page 2, for Model RA/RAD 350)

**Installation
Instructions (cont'd)**

**Section B - Applies to Option Package for Model RA/RAD 350
only (See FIGURE 2.)**

1. Assemble Vertical Louver Right Side Section

- a) Position the Top/Bottom Members for the Right Side (The square ends will be to the left and the mitered ends to the right.)
 - Position **top** right member with mounting **flange up** and **dimples down**.
 - Position the **bottom** right member with the mounting **flange down** and the **dimples up**.
- b) Attach the Louvers to the Top and Bottom Members
 - Using the sheetmetal screws, attach the vertical louvers with their edges extending beyond the front outer edge of the top and bottom members.
 - Stops are designed so that the louvers will turn **right**.

2. Assemble Vertical Louver Left Side Section

- a) Position the Top/Bottom Members for the Left Side (The square ends will be to the right and the mitered ends to the left.)
 - Position **top** left member with mounting **flange up** and **dimples down**.
 - Position the **bottom** left member with the mounting **flange down** and the **dimples up**.
- b) Attach the Louvers to the Top and Bottom Members

- Using the sheet metal screws, attach the vertical louvers with their edges extending beyond the front outer edge of the top and bottom members.
 - Stops are designed so that the louvers will turn **left**.
3. If the heater is installed, turn off the power supply before installing assembled vertical louver sections.
 4. **Install the Right Section** -- Position the assembly in front of the horizontal louvers so that the mitered edges line up with the inside edge of the corner post nearest to the burner. Using the mounting holes in the top and bottom flanges as guides, attach the louver assembly to the heater using the TEKS (self-drilling screws).
 5. **Install the Left Section** -- Position the assembly in front of the horizontal louvers so that the mitered edges line up with the inside edge of the corner post nearest to the large outer access panel. Using the mounting holes in the top and bottom flanges as guides, attach the louver assembly to the heater using the TEKS (self-drilling screws).
 6. Adjust both the horizontal and vertical louvers to provide the desired air pattern. If the heater is installed, restore the power and check operation.

FIGURE 2 - Vertical Louvers for RA/RAD350



- Assemble right and left vertical louver sections
- Position each section in the heater discharge in front of the horizontal louvers and attach
- Adjust louvers for desired air distribution. Do not adjust beyond stops.

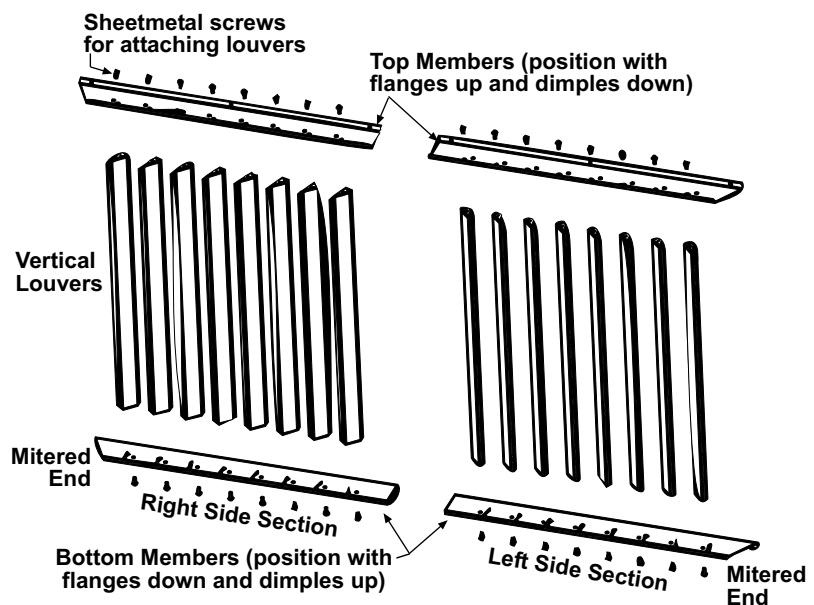

CAUTION: To avoid getting burned, adjust louvers while the heater is not in operation. If louvers are adjusted while the heater is in operation, wear protective gloves.

www.ReznorHeaters.com
(855) 854-3172

REZNOR®